

TO: Regional RCRA Senior Policy Advisors

As you know, the Administrator redelegated the delisting program to the Regional Administrators on October 25, 1995. I understand that the redelegation has proceeded smoothly and am very pleased with this result. You and your staff should be congratulated for this successful transition. Delisting was and will continue to be an evolving program as substantive technical and policy issues continued to develop. While working jointly with the Regions on a number of issues, we found it is important to have and maintain an appropriate level of national consistency among the Regional delisting programs.

The purpose of this memorandum is to transmit to you a national policy for the hazardous waste delisting program. It covers two important elements. First, the policy contains a "conditional delisting" element, designed to ensure that delisted wastes are managed in a manner consistent with the risk evaluation that supports the delisting decision. Second, the policy provides a delisting "reopener" element, designed to provide the Agency with a mechanism for immediate response to new information or data indicating conditions exist that may alter the Agency's position on the approval of a delisting. I recommend the application of each of these elements of this national policy to ensure the EPA delisting program remains safe and effective in protecting human health and the environment and at the same time achieves the goal of allowing the exit of certain wastes from the hazardous waste management system. The principles of this policy have been discussed among the Regional delisting coordinators during a series of monthly conference calls.

Background

In considering whether to exclude a particular solid waste from the list of hazardous wastes contained in 40 CFR 261.31 and 261.32, the Agency has historically considered disposal in an unlined landfill or surface impoundment to be representative of the reasonable worst-case

management scenarios for such waste. The Agency believes that it is appropriate to consider the worst-case management scenario because it is extremely difficult to project all potential management scenarios that can occur once the waste is delisted. Thus, the Agency generally has only modeled the risks related to these two disposal practices. The generic risk assessment model currently used (i.e., EPACML) or the model delisting may soon adopt (i.e., EPACMTP) are designed only to predict groundwater impacts for these two disposal scenarios (i.e., an unlined landfill and an unlined surface impoundment). These two models, as adapted to delisting, cannot predict risks resulted from exposures to wastes that are managed in other non-disposal scenarios, including uses constituting disposal and other recycling practices.

However, the Agency has generally not restricted how a delisted waste could subsequently be managed, provided it was managed in accordance with the applicable state's nonhazardous waste management requirements. Therefore, generators could decide to manage their waste in another, perhaps riskier, manner, and so the potential exposure from another and different management practice could pose greater environmental risks than the exposure scenarios modeled. For unconditionally delisted wastes, there is typically no legal impediment to these changes in management.

Conditional Delisting Policy

To reduce the uncertainty caused by the potential unrestricted use or management to delisted waste, it is important that new delistings apply only to wastes managed in the type of unit (e.g., "a landfill") modeled in the delisting risk assessment. For example, if the delisting determination modeled risks associated with disposal in landfills, the delisting would specify that the waste is delisted conditioned on disposal solely in a landfill. If the generator places the waste anywhere other than a landfill, the waste is a "hazardous waste" subject to RCRA Subtitle C regulation, unless otherwise exempted from regulation (i.e., 40CFR 266.20). The regulations in 40 CFR 266.20, which apply to recyclable materials (i.e., hazardous waste) used in a manner constituting disposal, impose certain requirements on such uses.

In the Agency's view, a conditionally delisted waste would exit the hazardous waste management system at the point it meets the established delisting levels, and would remain outside of the hazardous waste management system so long as the delisted waste generator complies with the conditions placed on the disposal of the delisted waste. The Regions should consider including appropriate mechanisms in conditional delistings that would help ensure that the waste was being managed in accordance with the conditions. For example, the Regions may consider adding a condition that the generator keep records, such as those they keep for business purposes, as to where they sent the waste.

EPA's policy of not considering site-specific factors when applying the fate and transport models remains unchanged. Therefore, at this time. Regions should not conditionally delist a waste based on consideration of protective site-specific hydrogeologic conditions (e.g., underlying clay) or specific landfill designs (e.g., liners, or covers). We would not be

comfortable at this time delisting a waste based on consideration of site-specific hydrogeologic conditions and specific landfill designs that would not be delisted based on a less site-specific analysis. While the Agency may consider a site-specific approach in the future, the Agency is not currently in a position to commit the necessary time and resources such site specific modeling evaluations would require and has not determined that this is an appropriate policy direction to take.

Nevertheless, the Agency realizes that for a relatively small number of petitioned wastes that are not (or will not be) managed under a scenario our generic delisting models can assess, Regions may have to consider site-specific circumstances or consider adding specific conditions, on a case-by-case basis. These cases are likely to raise issues of national significance, therefore, the Region should consult with the Office of Solid Waste.

Delisting Reopener Policy

In light of a recent experience that required the Agency to repeal an existing delisting, we recommend that the Regions include in future delistings, a provision that establishes a mechanism to review the delisting when additional data become available indicating the initial delisting decision was inappropriate or wrong. This is particularly important if the additional data shows that the delisted waste is not behaving in the disposal site as was predicted by the delisting risk assessment model. Therefore, Regions should include the following or similar language in future delisting decisions, unless there are clear rationales not to:

- (a) If, anytime after disposal of the delisted waste, [insert facility name] possesses or is otherwise made aware of any environmental data (including but not limited to leachate data or groundwater monitoring data) or any other data relevant to the delisted waste indicating that any constituent identified in Condition (x) is at a level in the environment (such as in the leachate or in the ground water) higher than the delisting level established in Condition (x), then [insert facility name] must report such data, in writing, to the Regional Administrator within 10 days of first possessing or being made aware of that data.
- (b) Based on the information described in paragraph (a) and any other information received from any source, the Regional Administrator will make a preliminary determination as to whether the reported information requires Agency action to protect human health or the environment. Further action may include suspending, or revoking the exclusion, or other appropriate response necessary to protect human health and the environment.
- (c) If the Regional Administrator determines that the reported information does require Agency action, the Regional Administrator will notify the facility in writing of the actions the Regional Administrator believes are necessary to protect human health and the environment. The notice shall include a statement of the

proposed action and a statement providing the facility with an opportunity to present information as to why the proposed Agency action is not necessary or to suggest an alternative action. The facility shall have 10 days from the date of the Regional Administrator's notice to present such information.

- (d) Following the receipt of information from the facility described in paragraph (c) or (if no information is presented under paragraph (c)) the initial receipt of information described in paragraph (a), the Regional Administrator will issue a final written determination describing the Agency actions that are necessary to protect human health or the environment. Any required action described in the Regional Administrator's determination shall become effective immediately, unless the Regional Administrator provides otherwise.

This language is intended to provide the Agency with a mechanism to review and act expeditiously on information that a previously granted delisting may be causing a threat to human health or the environment that was unknown at the time the Agency acted initially. Use of this language will provide you the ability to reopen, revoke, or otherwise suspend the delisting in a timely manner. Please share this national policy with the states within your Region that are authorized to administer their own delisting programs

This memorandum provides guidance to EPA personnel. The guidance is designed to communicate national policy regarding the RCRA delisting program. The memorandum does not, however, substitute for EPA's statutes or regulations, nor is it a regulation itself. Thus, it cannot impose legally-binding requirements on EPA, States, or the regulated community, and may not apply to a particular situation based upon the circumstances. EPA may change this guidance in the future, as appropriate.

If you have any question regarding this policy, please feel free to contact David Bussard, Director, Hazardous Waste Identification Division, at (703) 308-8887 or have your staff contact Rick Brandes, Chief, Waste Identification Branch, at (703) 308-8890.

cc: Regional Counsels David Nielsen. OECA

Electronic Filing - Received, Clerk's Office, June 30, 2008

ATTACHMENT 2

MAPQUEST.

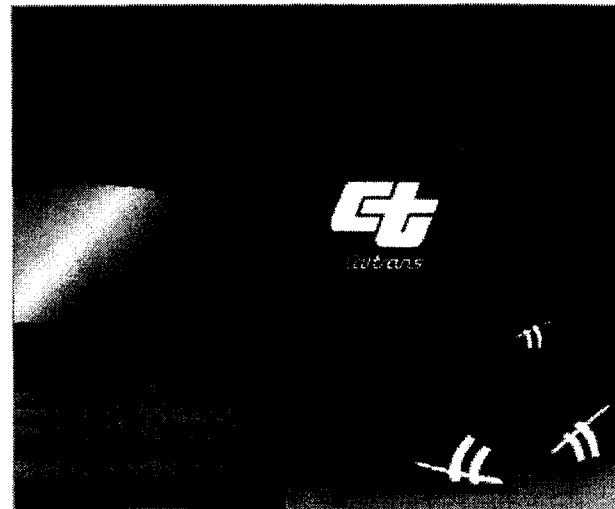

Note to Indiana I-80/94 Travelers in the Gary Area:

Beginning at 9:00 PM Monday through Friday, crews will restrict various lanes on the Frank Borman Expressway between Martin Luther King Drive and Central Avenue. Also, between midnight and 5:00 AM crews will close the roadway for up to 20 minutes at a time. Indiana State Police will be on hand to help direct traffic with the rolling closures. You may wish to verify your route on INDOT's Web site at [Borman Expressway](#). For your safety, always obey local construction and detour signs.

A: Davis Junction, IL

	1: Start out going SOUTHEAST on UNION ST toward IL-72.	0.0 mi
	2: Turn LEFT onto IL-72 E.	3.5 mi
	3: Merge onto I-39 S/US-51 S via the ramp on the LEFT toward LASALLE/PERU.	14.0 mi
	4: Merge onto I-88 E/RONALD REAGAN MEMORIAL TOLLWAY via EXIT 97A toward CHICAGO (Portions toll).	60.3 mi
	5: Merge onto I-294 S toward INDIANA (Portions toll).	24.3 mi
	6: Take I-294 EXPRESS S (Portions toll).	0.7 mi
	7: I-294 EXPRESS S becomes I-294 S (Portions toll).	6.4 mi
	8: I-294 S becomes I-80 E/I-94 E (Crossing into INDIANA).	17.3 mi
	9: Merge onto I-80 E/I-90 E via EXIT 16 toward OHIO (Portions toll) (Crossing into OHIO).	228.1 mi
	10: Merge onto OH-53 S via EXIT 91 toward FREMONT.	3.5 mi
	11: Merge onto US-20 E/OH-19 S via the ramp on the LEFT.	2.2 mi
	12: Take the CASTALIA ST/OH-412 ramp.	0.2 mi

Electronic Filing - Received, Clerk's Office, June 30, 2008

- ◆ 13: Turn LEFT onto OH-412/CASTALIA ST. Continue to follow OH-412. 7.5 mi

- ◆ 14: Turn LEFT onto CR-268/VICKERY RD. 0.6 mi

- END 15: End at Vickery, OH

Estimated Time: 6.0 hours 11 minutes Estimated Distance: 368.90 miles

B: Vickery, OH

Total Time: 6.0 hours 11 minutes Total Distance: 368.90 miles

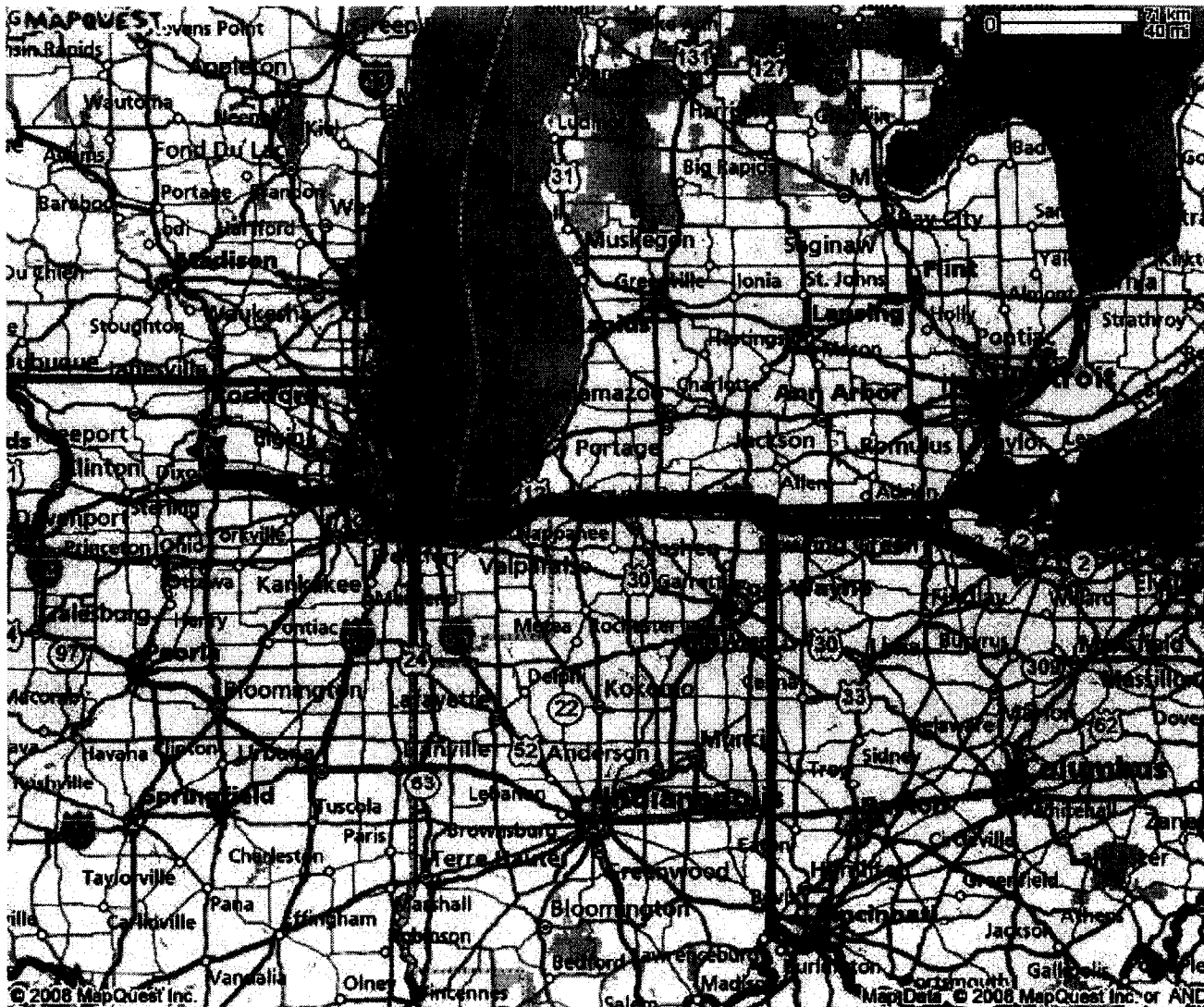

All rights reserved. Use subject to License/Copyright Map Legend
 Directions and maps are informational only. We make no warranties on the accuracy of their content, road conditions or route usability or expeditiousness. You assume all risk of use. MapQuest and its suppliers shall not be liable to you for any loss or delay resulting from your use of MapQuest. Your use of MapQuest means you agree to our [Terms of Use](#)

Hazardous Waste Delisting Petition

Shell Oil Company

Deer Park, Texas

January 20, 2003

Volume 1 of 2

Shell Deer Park Refining Company

A Division of Shell Oil Products Company LLC



P. O. Box 100
Deer Park, TX 77536

January 21, 2003

CERTIFIED MAIL - RETURN RECEIPT REQUESTED
#7002 0860 0005 5019 4724

Mr. Darrin Swartz-Larson
Chief OK/TX RCRA Permits Section
U.S. Environmental Protection Agency
Multimedia Planning & Permitting Division (6PD-O)
1445 Ross Avenue, Suite 1200
Dallas, Texas 75202-2733

Subject: Delisting Petition for the MTR Landfill Leachate
EPA I.D. TXD067285973
Shell Oil Company
Deer Park, Texas

Dear Mr. Swartz-Larson:

Shell Deer Park Refining Company, on behalf of Shell Oil Company (Shell), is pleased to submit one hard copy and one electronic copy of the Delisting Petition for the MTR Landfill Leachate. This petition is submitted in accordance with Region 6 RCRA Delisting Guidance Manual for the Petitioner. It is Shell's understanding that the EPA will acknowledge receipt of this petition by letter within five (5) days of receipt of this petition. Shell will, within seven (7) days of receipt of the EPA's letter, submit a public notice to the local newspaper regarding the submittal of the delisting petition to the EPA and will provide a copy to all persons on our facility mailing list. Shell will also send the EPA verification of this action (to be inserted in **Appendix B** of the Delisting Petition) within two (2) days of the publication of the public notice in the newspaper.

Electronic Filing - Received, Clerk's Office, June 30, 2008

We are sending the Texas Commission on Environmental Quality one copy of the Delisting Petition and will have one copy available in the Deer Park public library for public viewing. Please do not hesitate to contact Joe Phillips at (713) 246-1229 if you have any questions or concerns with this submittal.

Sincerely,

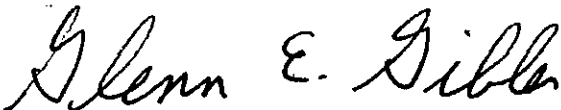

Glenn E. Gibler
Manager, Environmental & Compliance Assurance
Deer Park Refining Services
Agent for Shell Deer Park Refining Company

Enclosures

cc: **CERTIFIED MAIL - RETURN RECEIPT REQUESTED**
#7002 0860 0005 5019 4717

Registration and Reporting Section, MC-129
Texas Commission on Environmental Quality
P.O. Box 13087
Austin, Texas 78711-3087

HAZARDOUS WASTE DELISTING PETITION

FOR

SHELL OIL COMPANY

DEER PARK, TEXAS

VOLUME 1 OF 2

JANUARY 20, 2003

Prepared by:
Elizabeth Arceneaux, P.E., DEE
113 N. Johnson
San Marcos, Texas 78666
(512) 353-4720

TABLE OF CONTENTS

1.0 INTRODUCTION..... 1

1.1 OBJECTIVES..... 1

2.0 ADMINISTRATIVE INFORMATION SUMMARY..... 2

2.1 NAME AND ADDRESS OF PETITIONER..... 2

2.2 FACILITY CONTACT INFORMATION 2

2.3 LOCATION OF PETITIONED WASTE 2

2.4 DESCRIPTION OF PROPOSED ACTION..... 2

2.5 STATEMENT OF INTEREST IN PROPOSED ACTION..... 4

2.6 JUSTIFICATION FOR DELISTING..... 4

2.7 CERTIFICATION STATEMENT 5

2.8 PUBLICATION OF NOTICE 5

3.0 WASTE AND WASTE MANAGEMENT HISTORY INFORMATION 6

3.1 DESCRIPTION OF PETITIONED WASTE 6

3.2 HISTORY OF WASTE GENERATION..... 6

3.3 WASTE MANAGEMENT HISTORY..... 8

4.0 PROCESS AND WASTE MANAGEMENT HISTORY INFORMATION..... 10

4.1 GENERAL OPERATIONS AT THE GENERATING FACILITY 10

**4.2 OVERVIEW OF CONTRIBUTING MANUFACTURING
 PROCESSES 10**

**4.3 LANDFILL OPERATION AND LEACHATE COLLECTION
 SYSTEM..... 19**

4.4 DESCRIPTION OF WASTE MANAGEMENT UNITS 24

4.5 PROCESS MATERIALS AND WASTE VOLUMES..... 29

5.0 ANALYTICAL PLAN DEVELOPMENT..... 35

5.1 CONSTITUENTS FORMING BASIS OF LISTING..... 35

5.2	SELECTION OF ANALYTE LIST.....	35
6.0	WASTE SAMPLING INFORMATION	42
6.1	SAMPLING PERSONNEL INFORMATION	42
6.2	SAMPLING STRATEGY	42
6.3	SAMPLE COLLECTION AND IDENTIFICATION.....	42
6.4	SAMPLE PRESERVATION AND HANDLING.....	43
6.5	SAMPLING DOCUMENTATION	45
6.6	SAMPLE CUSTODY.....	45
6.7	QUALITY ASSURANCE/QUALITY CONTROL PROCEDURES	46
6.8	STATEMENT OF REPRESENTATIVENESS OF SAMPLES.....	46
7.0	WASTE ANALYSIS INFORMATION	47
7.1	ANALYTICAL LABORATORY INFORMATION.....	47
7.2	SUMMARY OF ANALYTICAL RESULTS	47
8.0	DATA EVALUATION USING EPA DRAS	59
8.1	INPUT VALUES.....	59
8.2	DELISTING LEVELS	60
8.3	CUMULATIVE RISK ASSESSMENT	60
8.4	SUMMARY.....	60

APPENDICES

- A** Quality Assurance Report
- B** Affidavit of Publication for Petition Submittal
- C** Field Logs and Laboratory Reports
- D** Laboratory Personnel Qualifications
- E** Calculation of Dioxin TEQs
- F** EPA DRAS Output Files

1.0 INTRODUCTION

Elizabeth Arceneaux, P.E. was retained by Shell Oil Company in Deer Park, Texas (Shell) to prepare a Hazardous Waste Delisting Petition (HWDP) for one waste stream currently generated at the facility. This HWDP was developed in accordance with the EPA Region 6 Hazardous Waste Delisting Program requirements.

1.1 OBJECTIVES

The objective of this HWDP is to provide documentation necessary for EPA to use in determining eligibility for delisting the petitioned waste. This petition contains information specified by EPA's guidance document titled: *Region 6 RCRA Delisting Program Guidance Manual for the Petitioner*. This information was collected from Shell documentation and from data collected as a result of implementation of the Sampling and Analysis Plan (SAP) developed for the facility and approved by EPA on May 31, 2002.

2.0 ADMINISTRATIVE INFORMATION SUMMARY

2.1 NAME AND ADDRESS OF PETITIONER

The complete name and address of the facility submitting this petition is as follows:

Mailing Address

Shell Oil Company
P.O. Box 100
Deer Park, Texas 77536-0100

Site Address

Shell Oil Company
5900 Hwy 225 East
Deer Park, Texas 77536

EPA Identification Number: TXD067285973

A site location map for the facility is presented as **Figure 2-1**.

2.2 FACILITY CONTACT INFORMATION

The following individual should be contacted for additional information relating to this petition:

Mr. Joe Phillips
Environmental Specialist
Shell Oil Company
P.O. Box 100
Deer Park, Texas 77536-0100
Phone: (713) 246-1229

2.3 LOCATION OF PETITIONED WASTE

Shell Oil Company
5900 Hwy 225 East
Deer Park, Texas 77536

2.4 DESCRIPTION OF PROPOSED ACTION

Shell operates a refinery and chemical-manufacturing complex in Deer Park, Texas. Products manufactured include gasolines, fuel oils, lubricants, base chemicals, specialty chemicals and sulfur. Facilities include refinery and chemical process units, feed/intermediate product storage tanks, dock/rail/truck shipping facilities and maintenance

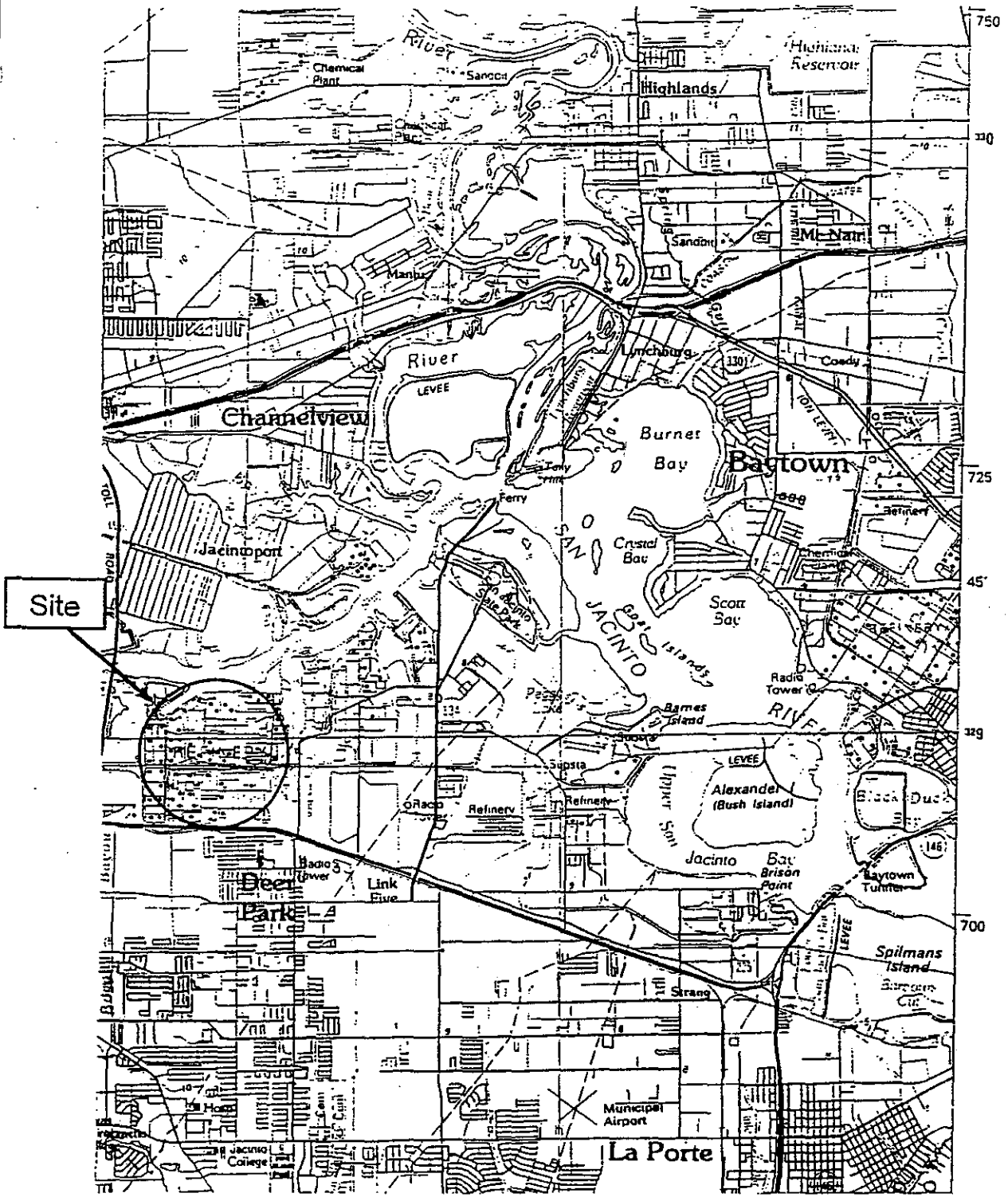

Produced by the United States Geological Survey

1:100 000-scale *metric* topographic map

Figure 2-1
Site Location Map
Shell Oil Company
Deer Park, Texas

DATE

2002

W.O.NO.

005-01

facilities. Shell generates hazardous and nonhazardous industrial solid wastes as a result of refinery and chemical processes, wastewater treatment, refinery/chemical plant feed, product storage and distribution.

Some of the hazardous and nonhazardous solid wastes are disposed of in an onsite, permitted hazardous waste landfill (MTR Landfill – Site 104). Leachate from this landfill requires offsite disposal as an F039 (multisource leachate) listed waste. However, analytical data collected monthly for this aqueous stream shows that it is not a characteristic waste and contains little to no detectable concentrations of organic constituents. Therefore, Shell is interested in seeking a conditional exclusion for the landfill leachate in accordance with §40CFR260.20, §260.22 and “EPA Region 6 RCRA Delisting Program Guidance Manual for the Petitioner.”

2.5 STATEMENT OF INTEREST IN PROPOSED ACTION

Based on comprehensive chemical analyses performed on samples collected, this waste does not exhibit the characteristics of a hazardous waste and does not meet the criteria for which it was listed.

Once delisted Shell plans to treat the leachate in the refinery's North Effluent Treater (NET) authorized under the National Pollutant Discharge Elimination Systems (NPDES) program. The leachate will be treated onsite and discharged rather than sent offsite for disposal at a permitted commercial facility.

2.6 JUSTIFICATION FOR DELISTING

Shell has performed extensive testing of the petitioned waste stream by undertaking a comprehensive sampling and analysis program. EPA was involved in developing the SAP and approved its use on May 31, 2002. Eight samples were collected of the waste (four primary and four secondary) and analyzed for a complete suite of parameters specified by the SAP. The waste was not found to be characteristically hazardous. A copy of the Quality Assurance Report for this project is included as Appendix A.

Using Region 6 Delisting Risk Assessment Software (DRAS), the analytical results also show that the waste does not contain levels of hazardous or nonhazardous constituents that would pose a significant risk to human health or the environment. The DRAS program evaluated a scenario assuming that the leachate were treated in a surface impoundment such as the NET onsite.

2.7 CERTIFICATION STATEMENT

I certify under penalty of law that I have personally examined and am familiar with the information submitted in this demonstration and all attached documents, and that, based on my inquiry of those individuals immediately responsible for obtaining information, I believe that the submitted information is true, accurate and complete. I am aware that there are significant penalties for submitting false information, including possibility of a fine and imprisonment.

Signed,

Dean Eshelman
Dean Eshelman
Plant Manager
Shell Chemical Company, Deer Park, Texas

MP Bellin
Tim Hake
President and CEO
Shell Deer Park Refining Company

Madonna V. Porter
Notary for Harris County

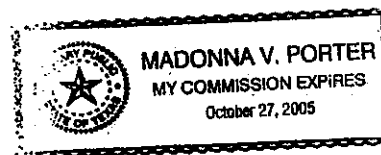

2.8 PUBLICATION OF NOTICE

A copy of the publication of notice regarding submittal of this petition is included in Appendix B.

3.0 WASTE AND WASTE MANAGEMENT HISTORY INFORMATION

3.1 DESCRIPTION OF PETITIONED WASTE

This plan covers a waste stream described as *MTR Landfill Leachate*. The F039 listing is for a multisource leachate. The leachate is a dark colored liquid and is collected from the primary and secondary leachate collection systems underlying the MTR hazardous waste landfill.

Figure 3-1 provides a basic schematic of waste input and operation of the MTR Landfill. The landfill occupies an area of approximately 17 acres and is being constructed in three stages, one cell at a time. Cell 3 was constructed in 1990 and closed in 1995. Cell 2 was constructed in 1995 and is currently active and receiving primarily nonhazardous solid wastes. Currently, there are no plans to construct Cell 1. The entire landfill is scheduled for closure by 2007.

As shown, the landfill has both a primary and secondary liner with a leachate collection system for both. The leachate is pumped from the collection systems to two hazardous waste storage tanks for the storage (<90-day) of primary leachate (tank T-323) and secondary leachate (tank T-324). The leachate has been combined in tanker trucks and disposed of as F039 listed waste at an offsite, permitted TSD facility.

The Texas Commission on Environmental Quality (TCEQ) has recently granted Shell permission to discharge the leachate into the Houston Ship Channel via NPDES permitted outfall R-007. The TCEQ granted this permission based on Shell's intention to have the leachate delisted, and it will be rescinded once the delisting process is complete.

3.2 HISTORY OF WASTE GENERATION

The MTR landfill began generating leachate around 1995 (Cell 3); however, the volume has increased substantially over the past 3-5 years. The leachate is transported offsite for disposal at an offsite permitted TSD facility on a monthly basis. The volume of leachate

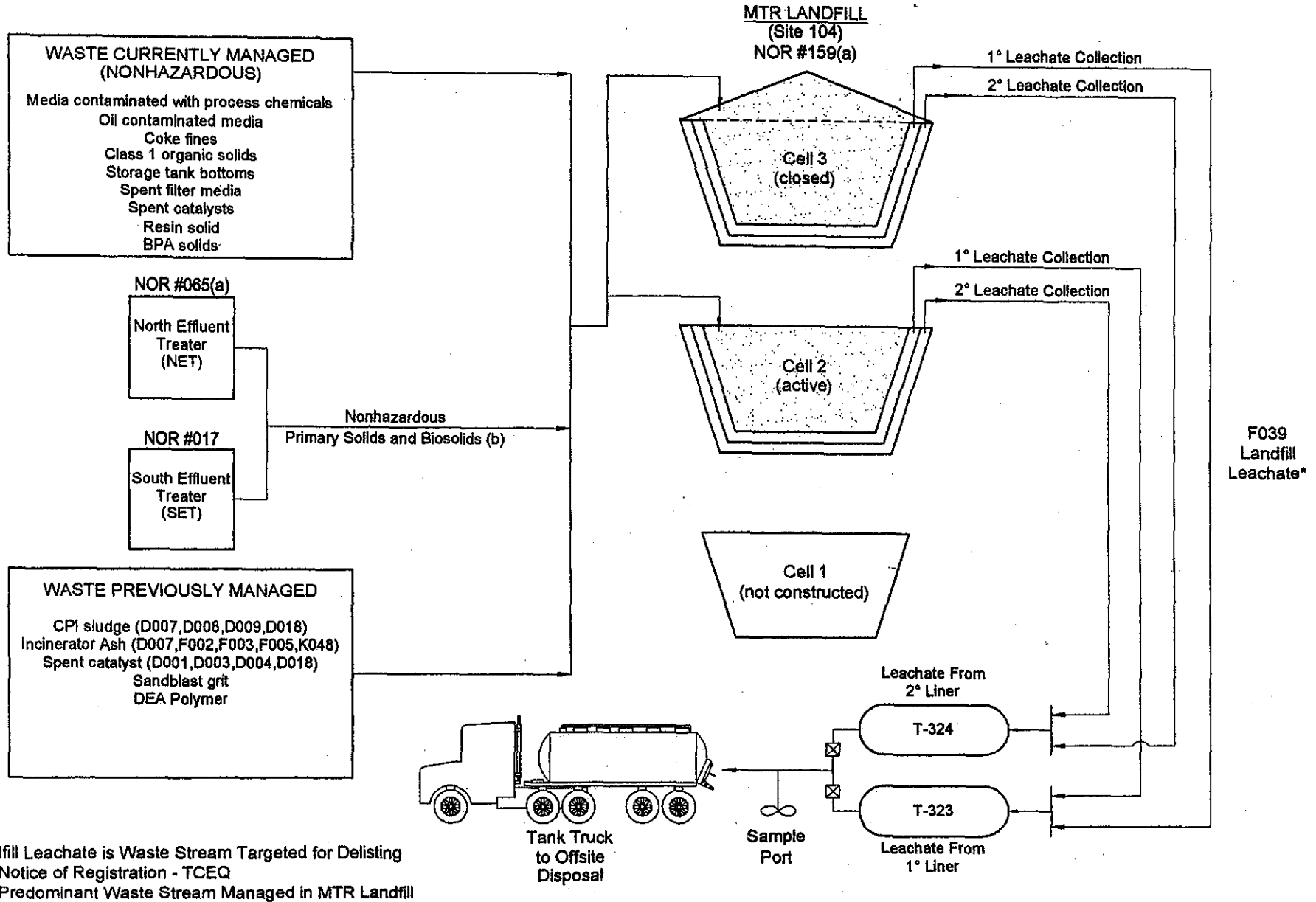

Figure 3-1
 Simplified Process Flow Diagram - Landfill Leachate
 Shell Oil Company
 Deer Park, Texas

DATE: October 2002

FILE NAME: Figure1-1.dwg

WORK ORDER NO.: 005-01

generated from 1999 to 2001 is shown below:

Year	tons/year (a)
1999	3,836
2000	9,237
2001	9,306
Annual Avg.	7,460
Annual Max.	9,306
Annual Max. assuming a 50% increase	14,000

(a) Based on Annual Waste Summary Reports submitted to the Texas Natural Resource Conservation Commission (TCEQ)

The annual maximum amount generated (as of 2001) is 9,206 tons. Shell would like to delist a volume 50% higher than this value to allow for future additional waste generation. The requested amount to delist in this petition is 14,000 tons (annual maximum). This is equivalent to 16,619 cy/year using the density of water (62.4 pounds/cf) to convert.

3.3 WASTE MANAGEMENT HISTORY

The landfill leachate is removed by vacuum truck from Tanks 323 and 324 on a monthly basis. The following hazardous waste disposal facilities have been used for offsite disposal of the leachate since 1998:

Texas Molecular (formerly Disposal Systems Inc.)
TXD000719518
2525 Battleground Road
Deer Park, Texas 77536
Deepwell injection

Laidlaw Environmental
TXD055141378
2027 Battleground Rd
Deer Park, TX 77536
Hazardous waste incineration

Chemical Waste Management
TXD000838896
Hwy 73, 3 miles west of Taylor Bayou
P.O. Box 2563
Port Arthur, TX 77643
Incineration and Deepwell injection

Duratherm, Inc.
TXD981053770
2700 Ave. S.
San Leon, Texas 77539
Hazardous waste fuel blending and recycling

If the leachate is delisted, Shell will make piping modifications to allow the leachate to be routed to the North Effluent Treater for treatment. The treated effluent is discharged through an NPDES permitted outfall (Permit: TX0004871, Texas permit #00403).

4.0 PROCESS AND WASTE MANAGEMENT HISTORY INFORMATION

4.1 GENERAL OPERATIONS AT THE GENERATING FACILITY

Table 4-1 provides a list of the raw products and refined products used and produced at this refinery. Shell Oil Company refines high sulfur crude oil from Mexico to products including gasoline, kerosene, jet fuel, fuel oil, lube oil and others. The facility occupies approximately 1600 acres in an industrial area on the south bank of the Houston Ship Channel. The Shell refinery portion of the facility is located generally north of the railroad tracks that cross the facility in an east/west direction.

The refinery consists of distillation, coking, cracking, reforming, hydrotreating and other production units. The production units and their design and production capacity are shown in Table 4-2.

4.2 OVERVIEW OF CONTRIBUTING MANUFACTURING PROCESSES

There were very few hazardous wastes managed in the MTR landfill. The hazardous wastes included incinerator ash, spent catalysts and filters, CPI sludge from the refinery wastewater treatment plant (North Effluent Treater) and primary solids from Shell Chemical and the South Effluent Treater (SET). The wastes disposed of in the MTR landfill for the past four years have been Class 1 and Class 2 nonhazardous wastes (Table 4-3). The following sections describe the contributing processes that generate the predominant hazardous and nonhazardous waste streams managed in the MTR landfill.

4.2.1 Incinerator Operations (Generates Incinerator Ash)

Shell once operated an incinerator to destroy biosolids sludge from both the refinery and chemical wastewater treatment plants. The waste ash carried the listing D007, F002, F003, F005, K048. Although there are no laboratory analyses available for the ash, Table 4-4 shows the constituents that formed the basis for listing the EPA codes. It is unlikely that the ash contained organic constituents, due to their destruction in the incinerator.

TABLE 4-1

Raw Materials, Intermediates, and Products
Shell Oil Company
Deer Park, Texas

<i>Parameter</i>	<i>CAS Number</i>
Raw Materials	
Crude Oil	8002-05-9
Major Intermediates	
Intermediates are consistent with refinery operations.	
Products	
MTBE	1634-04-4
Unleaded Gasoline	Mixture
Butane/Butylene	106-97-8
	68477-42-9
Domestic Jet Fuel	8008-20-6
Kerosene, Stove, Etc.	8008-20-6
Waxes	64742-61-6
	63231-60-7
Distillate Fuel Oil	68334-30-5
Residual Fuel Oil	68476-33-5
Motor and other Lube Oils	64742-54-7
	64742-18-3
Process Oils (Lubes)	64742-53-6
	64742-52-5
Isobutane and other Light Process Stocks	75-28-5
Natural Gasoline	8006-61-9
Sulfur	7704-34-9
Asphaltic Products	Mixture
Propane	74-98-61
Coke	64741-79-3

TABLE 4-2

Production Units and Capacities
Shell Oil Company
Deer Park, Texas

<i>Production Unit</i>	<i>Production Capacity (in MB/SD) (a)</i>	<i>Design Capacity (in MB/SD)</i>
Lube Crude Distillation	70.0	70.0
General Crude Distillation	204.5	210.0
Vacuum Distillation	104.5	115.0
	25.0	14.0
	9.5	25.0
Delayed Coking	65.0	65.0
Catalytic cracking	67.0	70.0
Reforming:		
Semi-Regen	24.5	27.0
Cyclic	47.0	47.3
Hydrocracking	67.0	68.5
Hydrotreating:		
Naphtha	65.0	65.0
Kerosene	37.0	37.0
Distillate	35.0	35.0
Cat Feed	45.0	49.5
Other	41.0	44.0
Lube	12.0	13.5
Alkylation (H ₂ SO ₄)	16.8	17.2
Methyl tert-butyl ether	5.7	5.7
Asphalt	4.7	4.7
Hydrogen:		
Steam/Methane Reformer	65.0	70.0
Pressure Swing Absorber	38.0	38.0
Coke (metric tons/day, 8% water)	4,122	4,122
Lube Processes:		
Deasphalting	4.2	4.2
Solvent Extraction	13.0	13.0
MEK Dewaxing	7.5	10.0
Deoiling (WAX)	2.4	2.4

NOTE:(a) MB/SD (thousand barrels per stream day) is capacity of unit on sustained basis

TABLE 4-3
Volume of Waste Disposed of in MTR Landfill (a)
Shell Oil Company
Deer Park, Texas

<i>Waste Type</i>	<i>TCEQ Waste Code</i>	<i>1998 Tons</i>	<i>1999 Tons</i>	<i>2000 Tons</i>	<i>2001 Tons</i>
DEA Polymer	00034031	25	0	0	0
Nonhazardous Resin Solid	01034031	655	1025	1066	0
BPA Solids	02014031	30	21.5	34	0
Chemical Primary Solids	03085031	9694	38	0	0
Biosolids – Refinery and Chemical Class 2	03056072	4479	0	0	0
Biological Treatment Sludge (organic)	03146071	0	1544	0	0
Sandblast Grit	07013891	232	86	0	0
Chemical Contaminated Media	60033011	1249	741	478	0
Oil Contaminated Media	70023011	2032	1769	1351	370
Nonhazardous Catalyst	80053931	3256	573	310	1
Nonhazardous Tank Bottoms	80103191	97	78	0	0
Nonhazardous Filter Media	80123101	170	105	66	0
Coke Fines	80264891	101	354	0	0
Class 1 Organic Solids	80294091	218	570	27	50
Plant Trash	80203191	0	0	50	0
TOTAL		22, 238	6,904	3,382	421

NOTES:

(a) Based on Annual Waste Summary Reports

TABLE 4-4

Potential Constituents in Incinerator Ash
Shell Oil Company
Deer Park, Texas

Basis for Listing (a)

D007

- Chromium

F002

- Tetrachloroethylene
- Methylene chloride
- Trichloroethylene
- 1,1,1-Trichloroethane
- 1,1,2-Trichloroethane
- Chlorobenzene
- Ortho-dichlorobenzene
- Trichlorofluoromethane

F003

- N.A.

F005

- Toluene
- Methyl ethyl ketone
- Carbon disulfide
- Isobutanol
- Pyridine
- 2-ethoxyethanol
- Benzene
- 2-nitropropane

K048

- Hexavalent chromium
 - Lead
-

NOTE: (a) 40CFR261, Appendix VII

4.2.2 Maintenance Activities (for spent catalysts, filters)

Many of the refinery processes use catalysts to facilitate the process and simplify the hardware. Depending upon the process unit, spent catalyst are either hazardous or nonhazardous. Hazardous spent catalyst is generally a listed waste from refining hydrotreating processes. Nonhazardous spent catalyst generally is from the Catalytic Cracking Unit (CCU).

Spent catalyst from the various hydrotreater units is generated during routine maintenance shut-downs (turn-arounds). A turn-around usually occurs every two years at the Shell Deer Park Refinery. The hazardous spent catalyst is usually sent off site for regeneration or disposal.

Spent catalyst from the CCU is generated as part of the process itself. New catalyst is inserted into the CCU on a daily basis with spent catalyst generated at the same rate. The spent catalyst is accumulated in hoppers and is disposed of every two weeks. In the past the spent catalyst has been disposed of in the MTR landfill. Currently, it is sent off site for recycling. The spent catalyst generally contains elevated levels of nickel and vanadium.

Nonhazardous filter media is generated during the routine maintenance of the various refinery scrubbers. These filters are used to filter particulates from the various process and scrubber streams throughout the refinery. DEA polymer, bisphenol acetone (BPA) solids, and filter media are all generated as part of the amine regeneration and scrubbing process. Amine solution is circulated through various refinery scrubbers to remove hydrogen sulfide from the process stream.

4.2.3 Refinery Wastewater Treatment Biosolids – Nonhazardous

As shown in Table 4-3, biological treatment sludge (biosolids) was disposed of in the landfill in 1999. Historical data for the sludge shows that it was disposed of in the landfill in relatively large quantities in the past. The biosolids are generated at the North Effluent Treater (NET) (unit number 065 on the TCEQ Notice of Registration). Figure 4-1 illustrates the NET treatment process and points of primary solids (CPI sludge) and biosolids generation.

The process wastewaters treated at the NET originate from refining and lubricant manufacturing units. Waters treated include process wastewaters, ballast waters, and water recovered from the oil recovery system. Stormwater from the Stormwater Impoundment Basin is also treated in the NET.

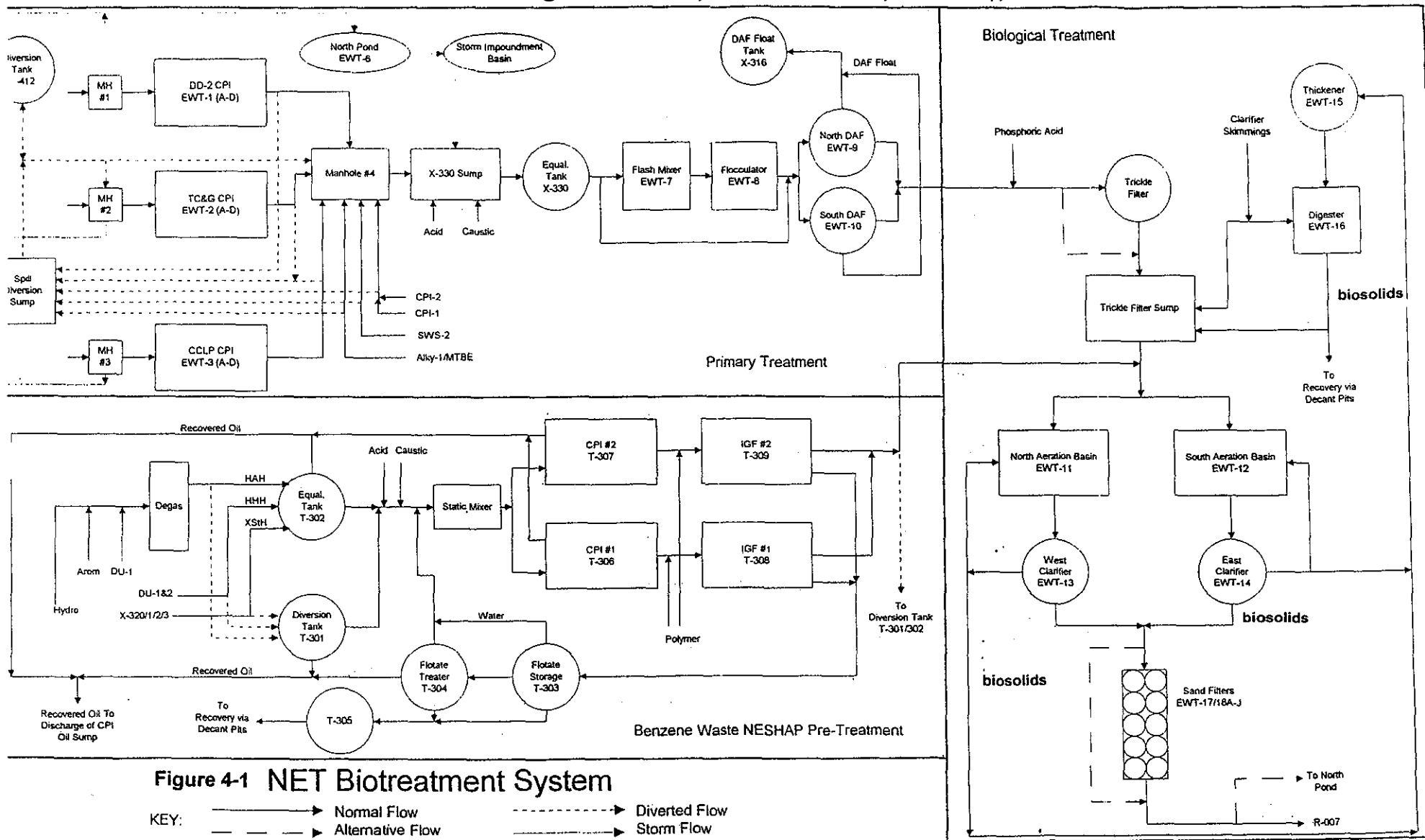

Five CPI's are located within the Refinery and at the NET. These CPI's provide the primary oil/water/solids separation step. Process waste, ballast water, and water recovered from the oil recovery system are all treated in the CPI's. The CPI discharge combines with stormwater from the Stormwater Impoundment Basin prior to neutralization using caustic and sulfuric acid. The neutralized water flows through an equalization vessel. Discharge of the equalization vessel is influent for the dissolved air flotation (DAF) unit (Intermediate oil/water separation). The DAF effluent is further processed through the biological treatment processes. These processes consist of a trickle filter and/or two activated sludge basins (North Aeration Basin, South Aeration Basin). Effluent from the basins is clarified in two gravity bed clarifiers and deep bed, monomedia, gravity flow filters prior to discharge through outfall R-007.

The biosolids collected off the clarifiers are processed through a thickener and digester to reduce the water and hydrocarbon content. The sludge flows through the thickener (40-foot diameter x 10 foot) with an average retention time of 13 hours. It is then digested in an 850,000-gallon aerobic digester for approximately 24 days. The dewatered sludge is then either disposed of in the MTR landfill, recycled in the refinery's coker unit or sent off site for disposal, depending on the hydrocarbon content. TCLP analyses performed in the past show that the sludge is not a characteristic hazardous waste once it has been processed through the thickener and digester. Recent analyses on the sludge show it is a Class 2 nonhazardous waste.

4.2.4 Resin

Resins are no longer manufactured at the Shell Deer Park Refinery, as that business was sold to a third party. Nonhazardous resin solids were generated at the Resins plant during the cleanup of various spills from either the resin solidification process and/or during the bagging operations. The spilled resin was picked up along with dust, dirt and other media during cleanup of the process area. Resin solids also includes filter sludge, bag dust, pipe clean out and vessel clean out of solidified resin.

4.2.5 Shell Chemical Primary Solids

Chemical primary solids consist of sludge and solids that settle in the API separators in the Shell Chemical Plant. Primary solids, consisting of mainly calcium carbonate, also collect in the primary clarifiers of the South Effluent Treater (SET) (unit number 017 on the NOR). **Figure 4-2** illustrates the SET wastewater treatment process. These solids may have residual oil and resin, but are nonhazardous waste. The SET treats wastewater from the chemical units that produce oxygenated solvents, olefins, resins, vinyl chloride monomer and phenol

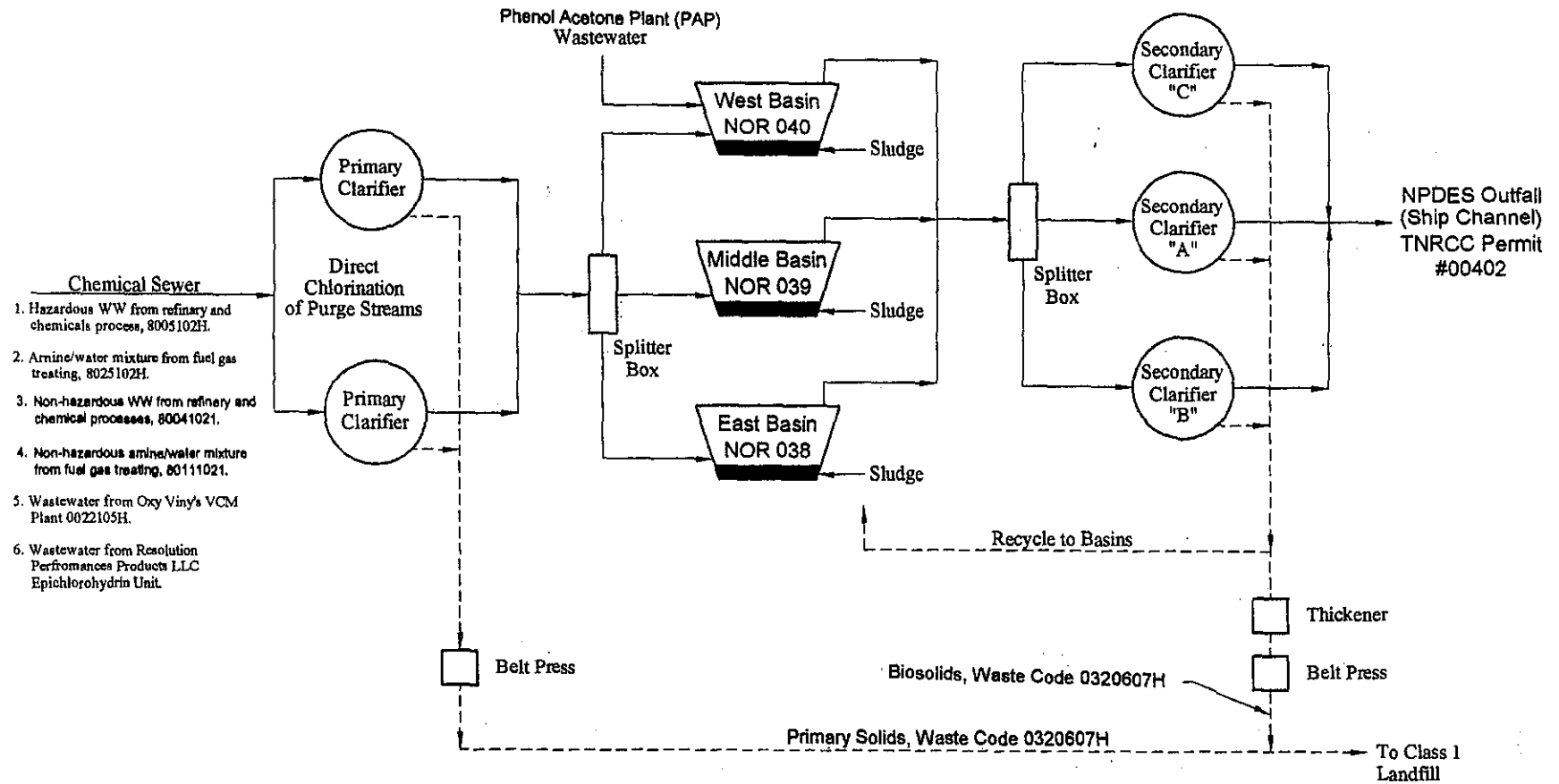

FIGURE 4-2
 Simplified Process Flow Diagram
 South Effluent Treater (SET)
 Shell Chemical-Deer Park, Texas

DATE: November 2002

FILE NAME: Figure1.dwg

WORK ORDER NO.: 005-01

acetone. Chemical analysis of the primary solids (6/23/00) show that the waste is not a characteristic hazardous waste. Because the SET treats a listed wastewater from OxyVinyls (K017, K019, K020), the solids generated from treatment of the chemical wastewater might be considered hazardous due to the derived-from rule. Shell is working with the TCEQ to gain clarification on the regulatory status of these solids. OxyVinyls submitted a delisting petition to EPA on October 11, 2002 to delist the wastewater for these waste codes.

4.2.6 Shell Chemical Biosolids

The biosolids are generated in the east, middle, and west aeration basins of the SET. They consist of biomass and floc that form the aerobic digestion of the chemical wastewater. The solids are separated in the three clarifiers that follow the aeration basins. Excess biosolids are processed through a thickener and filter press and transported off site for disposal. In the past, biosolids were disposed of in the MTR. Chemical analysis of this waste stream in June 2000 showed that the waste is not hazardous due to characteristic and the Total Petroleum Hydrocarbon content was less than 50 mg/kg. The biosolids, like the primary solids, may carry the K017, K019 and K020 listing until either OxyVinyls' wastewater is delisted or regulatory status is determined.

4.2.7 Oil Contaminated Media

Oil contaminated media includes Class 1 waste consisting of soil from spill cleanups and from construction areas contaminated with oil (TPH). This waste also includes rags, personal protective equipment/clothing and spent absorbents/pads/booms contaminated with nonhazardous oil.

4.3 LANDFILL OPERATION AND LEACHATE COLLECTION SYSTEM

The MTR landfill consists of three cells, a leachate collection system and two less-than-90 days leachate storage tanks. Cell 3 was constructed in November 1990 and capped in 1995. Cell 2 was constructed in September 1995 and is open, and Cell 1 has not been constructed. The landfill is currently scheduled for closure in 2007. **Figure 4-3** shows a plan view of the landfill and the leachate collection and storage system.

4.3.1 Landfill Design

The landfill is designed to meet the minimum technological requirements (MTR) specified in 40CFR264.301. This includes design requirements of a primary leachate collection system and liner (underlying the deposited waste) followed by a secondary leachate

NOTES:

1. FOR GENERAL NOTES SEE DWG. E-105550.

REFERENCE DRAWINGS:

- E-105550 CIVIL/STRUCTURAL GENERAL NOTES
- E-105552 GRADING AND DRAINAGE PLAN
- E-105553 STORAGE/TRUCK LOADING FACILITY FOUNDATION
- E-105557 PUMP CONTAINMENT BOX FOUNDATION DETAILS
- E-105558 PUMP CONTAINMENT BOX SUPPORT STRUCTURE

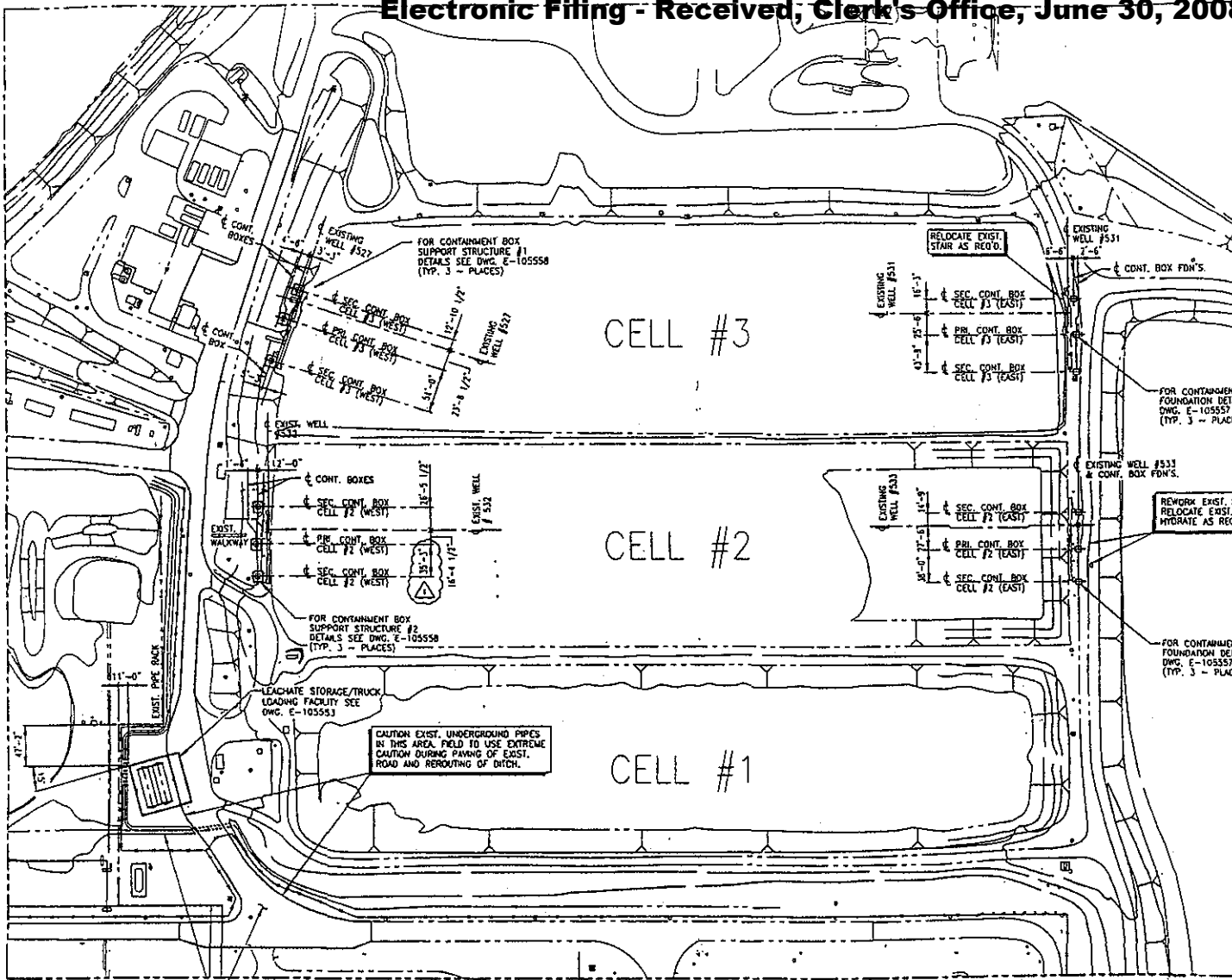

Russell C. Dionne

ISSUED FOR
 SEP 05 2001
 RECORDS
 Figure 4-3
 Plan View of Landfill and
 Leachate Collection Tanks

DRAWING CODE: 02B3.225.625

DEER PARK MANUFACTURING COMPLEX
 SHELL OIL COMPANY - SHELL CHEMICAL COMPANY
 DEER PARK REFINING LIMITED PARTNERSHIP

PAVING & FOUNDATION LOCATION PLAN
 LEACHATE COLLECTION AND STORAGE SYSTEM
 ENVIRONMENTAL N. E. WASTE TREATING AREA

REVISIONS				ACCOUNT NUMBER: 02B3225-0-01			
NO.	DATE	BY	DESCRIPTION	NO.	DATE	BY	DESCRIPTION
1	1/18/01	DMH/MSK	ISSUED FOR CONSTRUCTION	DMH	JAN 18 2001	DMH	ISSUED FOR CONSTRUCTION
2	1/18/01	DMH/MSK	CHANGE 1 REVISION	DMH	JAN 18 2001	DMH	CHANGE 1 REVISION

DATE	BY	APPROVED	DATE	BY	APPROVED
CHECKED: JAN 18 2001	JAG	APPROVED:	DATE: 03-05-01	DMH	NO.
APPROVED: FEB 1 2001	FDB	APPROVED:	DATE:	NO.	

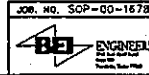

collection system and liner (underlying the primary liner). **Figure 4-4** shows the components of the primary and secondary leachate/liner systems.

4.3.2 Leachate Collection System Design

This landfill design includes a series of liners and leachate collection systems that envelope the deposited waste to prevent migration of wastes and leachate out of the landfill. Just beneath and in direct contact with the waste is the upper or primary leachate collection system. This system includes (beginning at the top) a three-inch sand layer, a layer of geotextile fabric, and a gravel layer whose thickness varies from 0.5 to 1.5 feet. Two eight-inch perforated leachate collection pipes are located within the gravel layer and are in turn contained in two east-west trenches of each half cell.

The eight-inch pipes connect on one end of the cell to a 12-inch perforated pipe which is perpendicular to the collection pipes and is contained in a two-foot deep sump at the outer end of each half cell. Each end of the 12-inch headers is capped. Two 12-inch stand pipes, also referred to as well casings, connect to the sump pipe in each half cell. The stand pipes are at right angles to the sump pipe and extend along the 1V:2H slope, following the inner face of the perimeter dike to the top of the landfill. Leachate filters through the sand layer into the gravel layer. The high permeability gravel layer permits the rapid flow of leachate along a two percent slope in a north or south direction, toward the two east-west oriented trenches. The primary leachate collection system components slope from the center dike into a lengthwise direction in each half-cell toward the collection sumps.

The primary liner is immediately below the gravel layer. The primary liner is a single, flexible membrane of 100-mil high-density polyethylene (HDPE) material. This liner follows the same contours and slopes as the primary leachate collection system sand and gravel layers. The primary liner covers the sides and the bottom of the landfill. The purpose of this liner is to contain all leachate so that it can be collected and removed from the landfill.

If leachate penetrates the primary liner, it is collected in the secondary leachate collection system. This system is located immediately below the primary liner and consists of a 250-mil HDPE drainage netting (see **Figure 4-5**). The length of the leak detection system is interrupted at intervals by 6 percent bentonite clay dams to divide the bottom area of the half cell into compartments. In the trenches, each dam is penetrated by one to four leachate collection/test pipes. Each of the four pipes in a trench has a different length and is perforated only at the end position that is between dams. This means that each pipe would

Figure 4-4
Primary and Secondary Leachate Collection Systems
Site 104, MTR Landfill
Isometric View

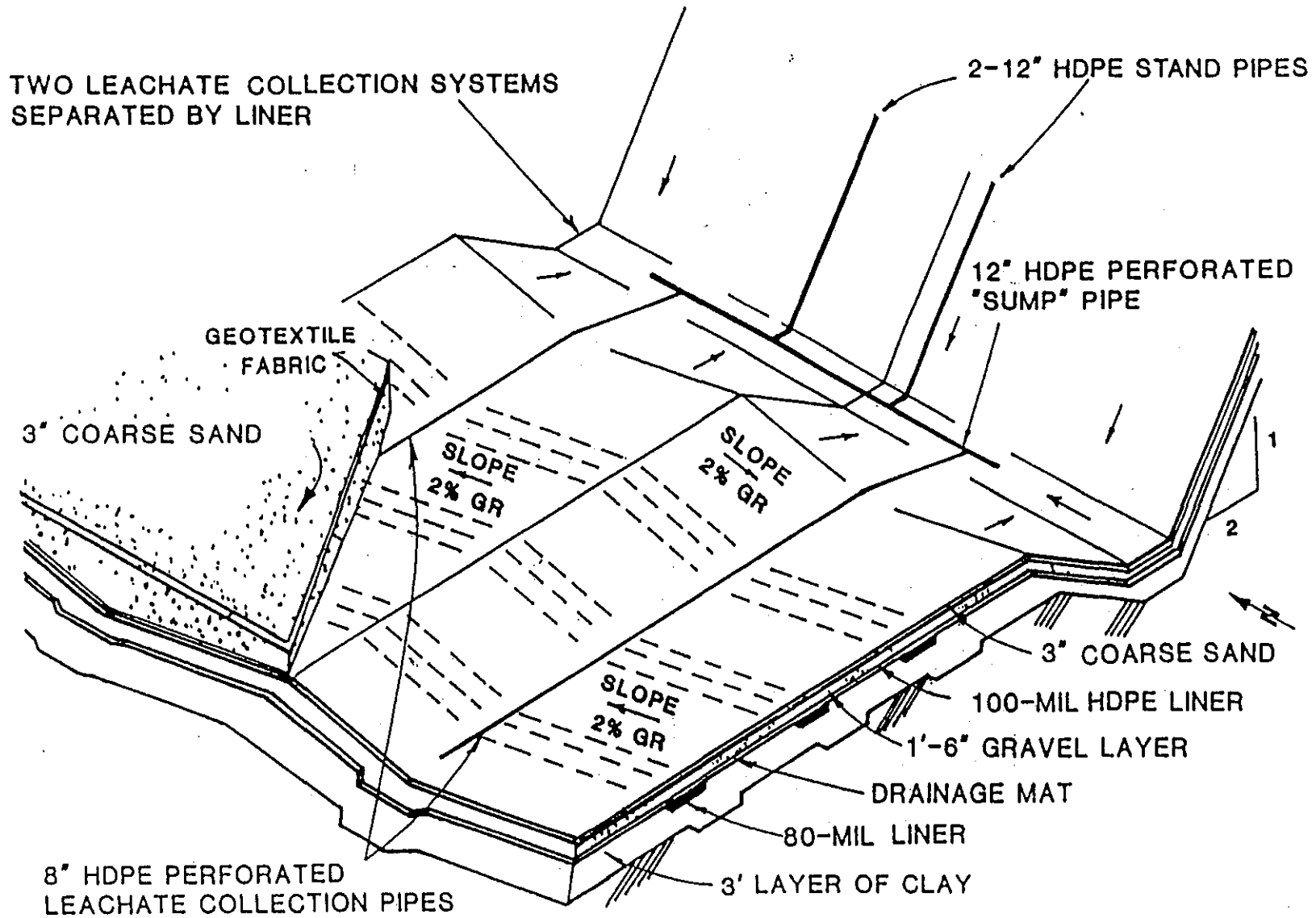

Secondary Leachate Collection Systems

Site 104, MTR Landfill

Isometric View

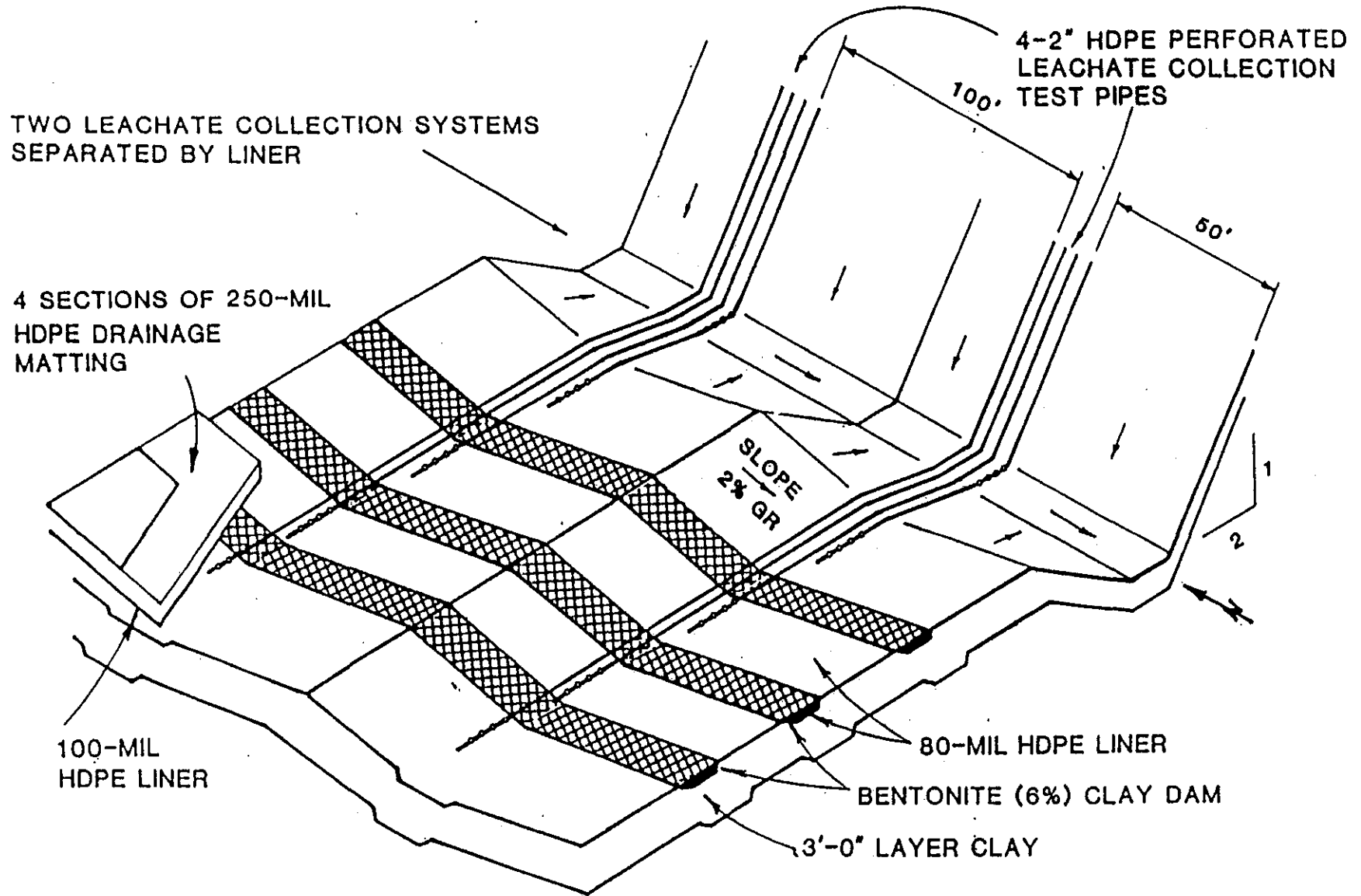

collect leachate from a single but different compartment. Utilizing this design enables the identification of the area of the primary liner where a leak is indicated. The HDPE drainage mat is designed to allow the rapid flow of leachate to the collection pipes below.

Beneath the drainage mat and collection pipes of the secondary leachate collection is the secondary liner, which is an 80-mil HDPE flexible membrane and a 3-foot thick clay liner. The HDPE liner, like the primary liner, completely covers the bottom of the cell and extends up the side walls of the containment dikes. The flexible membrane liner is in direct contact with and is supported by a three-foot basal clay, low permeability liner (1×10^{-7} cm/sec permeability). This compacted clay soil liner is designed to follow a two percent slope toward the two east-west oriented trenches.

4.3.3 Leachate Collection Storage Tanks/Truck Loading

The storage facility consists of two 1,000-barrel aboveground storage tanks; one for leachate collected from the primary collection system (T-323) and one for the secondary collection system (T-324). The tanks are supported by steel structures placed on a concrete slab. The slab is surrounded by a 3-ft high concrete retaining wall providing secondary containment. A tank truck-loading pad is constructed outside the secondary containment area. The storage facility is equipped with piping, valves, and pumps to load leachate into tank trucks for offsite disposal. The storage tanks are equipped with automated level sensors to detect spills and overfills. The two tanks have valves that allow the trucks to load either from the primary or secondary leachate tanks, or from both simultaneously. A sample port is located between the pump and the loading pipeline to the truck.

4.4 DESCRIPTION OF WASTE MANAGEMENT UNITS

There are 7 hazardous waste treatment and storage units at the refinery. The hazardous waste management units include one hazardous waste landfill (MTR Landfill), three container or dumpster storage areas, one wastewater treatment unit (NET), one waste pile, and one pond (North Pond). The locations of these units (as identified by the NOR number) are shown in **Figure 4-6**. Some of the units are exempt from permitting. The landfill is authorized under the RCRA Permit No. HW-50099-001, issued by the TCEQ and EPA. **Table 4-5** lists the unit, its NOR number and the hazardous waste streams managed in each.

Hazardous wastes generated at the Shell refinery include CPI sludge, DAF solids, primary solids and IGF float from the refinery wastewater treatment plant (i.e., North Effluent

TABLE 4-5
 Hazardous Waste Management Units in the Refinery
 Shell Oil Company
 Deer Park, Texas

<i>Hazardous Waste Management Unit</i>	<i>Hazardous Waste Managed</i>	<i>TCEQ Waste Code</i>
NET Refinery WWTP NOR Facility 065 (a)	Groundwater, hazardous	0312102H
	Spent acid solutions	8007104H
	Spent caustic solutions	8008109H
	Hazardous wastewater from refinery and chemical processes	8019102H
	Amine/water mixture from fuelgas treating units	8025102H
	<u>Previously Managed at NET:</u>	
	Refinery biosolids, hazardous	0302607H
	Washwater with residue from combustion of phenol heavy ends	1705114H
	Wastewater contaminated with refinery listed waste	7007102H
Waste Pile NOR Facility 155	All nonhazardous waste	N/A
		<u>Previously Managed at Waste Pile:</u>
	Amine/water mixture from fuelgas treating units.	8025102H
Container Storage Area-Paint Yard NOR Facility 158	Paint liquid	0704209H
	Paint solid	0705409H
MTR Landfill - Site 104 NOR Facility 159	Nonhazardous waste	N/A
		<u>Previously Managed at MTR:</u>
	CPI Sludge from refinery effluent treater	0307503H
	Incinerator Ash, hazardous	0311303H
	Catalyst, hazardous, spent	8006393H
	Spent filter media, hazardous	8013310H
	Primary and biosolids from chemical wastewater treatment	0320607H

Table 4-5
(Continued)

<i>Hazardous Waste Management Unit</i>	<i>Hazardous Waste Managed</i>	<i>TCEQ Waste Code</i>
<i>Container Storage Areas NOR Facilities 165, 167</i>	Paint liquid	0704209H
	Paint solid	0705409H
	Lab packs	0902003H
	Spent acid	0903103H
	Laboratory wastewater	0904105H
	Contaminated soil	1701301H
	Phenol heavy ends	1702208H
	Phenolic liquid wastes	1704208H
	Spent sulfuric acid	5202602H
	Heat exchanger cleaning liquids	7003114H
	Clarified slurry oil storage tank sediment	7006319H
	Catalyst, spent	8006393H
	Spent filter	8013310H
	PCB contaminated media	8016319H
	Filter media	8024404H
	Pyrophoric solids	8032405H
	Tank seals	8038409H
	Misc. listed organics	8017207H
	Heat exchanger solids	7001319H
	Refinery hydrotreater catalyst	7004393H
	Refinery crude oil storage tank solids	7005319H
	Storage tank bottoms solids, hazardous, from refinery and chemical plant storage tanks	8018319H
	Media contaminated with lead	8039319H
	IRU Polymer waste reactivated	0005403H
	Broken fluorescent lightbulbs, containing mercury	0906388H
	Washwater with residue from combustion of phenol heavy ends	1705114H
	Debris contaminated with K022 wastes	1706319H
	Chrome contaminated media	8009319H

Table 4-5
(Continued)

<i>Hazardous Waste Management Unit</i>	<i>Hazardous Waste Managed</i>	<i>TCEQ Waste Code</i>
<u>Previously Managed at CSA:</u>		
	Resin Waste	0102219H
	Resin Waste	0104403H
	Corrosive Solids	8031319H
	Incinerator Ash, Hazardous	0311303H
	ECH, liquid	0607207H
	Spent Ni-Cd Batteries	0710309H
	Spent acetonitrile	0001203H
<i>North Pond</i> NOR Facility 102	CPI sludge from refinery BWN (benzene waste NESHAPS) pretreatment unit	0310503H
<i>Leachate Storage Tanks T-323, T-324</i> Less than 90-day tanks NOR Facilities 185, 186	Landfill leachate	0301116H

Notes:

(a) NOR = TCEQ Notice of Registration, dated 11/5/02

Treater, NET); incinerator ash; spent catalyst; spent filter media; waste paint; lab packs; spent acids and spent caustic solutions.

A list of the hazardous wastes generated at Shell is shown in Table 4-6 along with the TCEQ and EPA waste codes for each. Wastes that are landfilled onsite currently or in the past are identified with an asterisk.

A list of permits held by Shell Oil follow:

Hazardous Waste: RCRA permit number HW50099-001

NPDES Permit: TX0004871

TPDES Permit: 00403

Air Permit: TX815, H60656F, H60659W

4.5 PROCESS MATERIALS AND WASTE VOLUMES

The primary raw product used in the refining process is a sour crude oil. Nickel and vanadium-based catalysts are also used in the refining process.

The volume of the waste streams sent to the MTR landfill from 1998 through 2001 was shown previously in Table 4-3. Oil contaminated media and chemical contaminated media make up a large volume of waste disposed of in the landfill over the past four years. Spent nonhazardous resin and catalyst also make up a large proportion of waste consistently disposed of in the landfill. Biosolids and chemical primary solids were sporadically disposed of in large quantities.

The volume of leachate collected from the primary and secondary containment systems is shown in Table 4-7 for the past three years. The volume is measured in terms of the combined volumes from Tanks T-323 and T-324. These data were taken from monthly manifest logs and Shell's Annual Waste Summaries submitted to the TCEQ.

As shown the amount of leachate generated and disposed of offsite has increased over the past three years. Shell is currently investigating the source of leakage into the primary and secondary systems. To date the maximum monthly volume generated is approximately 1,277 tons and the annual maximum is 9,306 tons. To allow for an approximate 50% increase in volume, Shell is requesting to delist an annual maximum volume of 14,000 tons.

TABLE 4-6
 Hazardous Wastes Generated at Shell Oil Company (a)
 Deer Park, Texas

<i>Description</i>	<i>TCEQ Waste Code (b)</i>	<i>EPA Waste Code</i>
Spent acetonitrile	0001203H	D001, D018, U003
IRU Polymer waste reactivated	0005403H	D001
Landfill leachate from onsite hazardous waste landfill	0301116H	F039
DAF unit float, skim and bottoms from refinery wastewater treater	0303205H	D018, K048
API skimmings from chemical process units' wastewater treater	0304207H	D001, D018, D035
CPI sludge from refinery wastewater treater*	0307503H	D007, D008, D009, D018, F037
IGF float generated from refinery wastewater induced gas floatation units	0309205H	D018, F038
CPI sludge from Refinery BWN pretreatment unit	0310503H	D018, F037
Groundwater, hazardous	0312102H	D018, D028, D043
Biosolids, chemical, hazardous	0316607H	K174
API sludge, chemical, hazardous	0317609H	D018
Paint liquids waste materials	0704209H	D001, D005, D035, F002 F003, F005
Paint solids waste materials	0705409H	D001, D005, D035, F002 F003, F005

TABLE 4-6
(continued)

<i>Description</i>	<i>TCEQ Waste Code (b)</i>	<i>EPA Waste Code</i>
Lab packs, hazardous, mixed	0902003H	D001, D002, D003, D011, D018, D019, D022, D028, D035, D040, F002, F003, F005
Spent acid containing mercury salts generated during lab testing	0903103H	D001, D002, D009, D011
Mercury salts and contaminated media	0905316H	D009
Broken fluorescent bulbs containing mercury	0906388H	D009
Soil contaminated with listed commercial chemical product	1701301H	U002, U031, U041, U055, U140, U161, U165, U188
Phenol heavy ends (distillation bottoms) generated from the production of phenol and acetone from cumene	1702208H	D001, K022
Phenolic liquid waste from loading, drips and spills	1704208H	U188
Washwater with residue from combustion of phenol heavy ends	1705114H	D002, K022
Debris contaminated with K022 waste	1706319H	K022
Spent sulfolane sludge with benzene	5202602H	D018
Heat exchanger cleaning solids from refinery exchanger cleaning	7001319H	D007, D008, K050
Heat exchanger cleaning liquids from refinery exchanger cleaning	7003114H	K050

TABLE 4-6
(continued)

<i>Description</i>	<i>TCEQ Waste Code (a)</i>	<i>EPA Waste Code</i>
Refinery hydrotreater catalyst, spent	7004393H	D001, D003, D004, D018, K171
Refinery crude oil storage sediment	7005319H	K169
Clarified slurry oil storage tank sediment	7006319H	K170
Catalyst, hazardous, spent*	8006393H	D001, D003, D004, D018
Spent acid solution	8007104H	D002
Spent caustic solutions	8008109H	D002, D018
Chrome contaminated media	8009319H	D007
Spent filter media contaminated with hazardous compounds*	8013310H	D001, U002, U003, U031, U041, U140, U159, U161
PCB contaminated media	8016319H	D001
Misc. listed organics from spills, drips, etc.	8017207H	D001, D018, D035, U002, U031, U140, U159, U161
Storage tank bottom solids from refinery/chemical plant storage	8018319H	D001, D018, D035, K169, K170, U031, U140
Wastewater from refinery/chemical production facilities	8019102H	D007, D018, D022, D026, D028, D035, D038
Wastewater received from co located facility	8022102H	K017, K019, K020
Filter media contaminated with benzene	8024404H	D001, D018
Amine/water mixture from fuel gas treating units, contains benzene	8025102H	D018
Pyrophoric solids	8032405H	D001

TABLE 4-6
(continued)

<i>Description</i>	<i>TCEQ Waste Code (a)</i>	<i>EPA Waste Code</i>
Tank seals	8038409H	D001, D018
Media contaminated with lead	8039319H	D008
<u>No longer generated wastes</u> (only listed below if it was disposed of in the MTR Landfill)		
Hazardous incinerator ash*	0311303H	D007, F002, F003, F005, K048
Paint wastes, liquid*	910650	F002, F003, F005
Sulfur-polymer*	948880	none
Biosolids, hazardous from refinery wastewater treater	0302607H	K048

NOTES:

- (a) Also includes wastes generated by Shell Chemical Company located within the same complex.
- (b) TCEQ = Texas Commission on Environmental Quality
- * Wastes disposed of in the MTR landfill (presently or in the past).

TABLE 4-7
 Volume of MTR Landfill Leachate
 Shell Oil Company
 Deer Park, Texas

Waste Name	1999 Tons	2000 Tons	2001 Tons
◆ MTR Landfill Leachate	3,836	9,237	9,306

MTR Landfill Leachate (a)

Monthly Avg. = 622 tons
 Monthly Max. = 1,277 tons
 Annual Avg. = 7,460 tons
 Annual Max. = 9,306 tons

Shell wants to increase the maximum volume of 9,306 tons by approximately 50% to allow for potential future leachate volumes.

$$9306 \text{ tons/year} \times 1.5 = \text{app. } 14,000 \text{ tons/year}$$

5.0 ANALYTICAL PLAN DEVELOPMENT

5.1 CONSTITUENTS FORMING BASIS OF LISTING

Table 5-1 shows the list of constituents for the F039 multisource leachate for which the waste was listed in 40 CFR 261, Appendix VII. The constituents are volatile organics, semivolatile organics, metals, pesticides, herbicides, dioxins and furans. Appendix VII of 261 refers to 40 CFR 268.43(a) for the list and states that the F039 listing includes "all constituents for which treatment standards are specified for multisource leachate".

5.2 SELECTION OF ANALYTE LIST

As part of the Sampling and Analysis Plan (SAP) for the petitioned waste stream, an analyte list was developed. The components of the list were based on process knowledge and previous analytical data. The list was reviewed and approved (with modifications) by EPA.

The analytes included on a total basis are the Appendix IX list of metals, volatiles, semivolatiles, pesticides, herbicides, PCBs and dioxins/furans. The Appendix IX constituents are a refined list taken from the Appendix VIII list of hazardous constituents. The Appendix IX list includes the constituents for which the Shell waste was listed, the constituents detected in the wastes, and any other compounds that may exist as byproducts of combustion (i.e., for the incinerator ash disposed of in the past).

Dioxins and furans may form as a byproduct from the incineration of chlorinated aromatic compounds such as chlorinated phenols, pesticides and PCBs (API, 1990, Dioxins and Furans – A Primer. Pub #4506). These compounds are included in the analytical program. A 2,3,7,8-TCDD equivalent was calculated for each set of dioxin/furan analyses using EPA methodology.

The Appendix IX pesticides, herbicides and PCBs were included in the analyte list as a conservative measure. These compounds are not used as raw products for contributing processes and are not generated as a result of process operations. In accordance with Section 6.6.2 of the "EPA RCRA Delisting Program Guidance Manual for the Petitioner" the waste streams samples were also analyzed for the following additional analyses:

- Total oil and grease;
- Total cyanide and sulfide;
- Ignitability and corrosivity

TABLE 5-1

Basis for Listing Hazardous Waste
 40 CFR 261, Appendix VII
 Shell Oil Company
 Deer Park, Texas

F039	F039 (continued)
<ul style="list-style-type: none"> ● Acenaphthene ● Acenaphthylene ● Acetone ● Acetonitrile ● Acetophenone ● 2-Acetylaminofluorene ● Acrolein ● Acrylonitrile ● Aldrin ● 4-Aminobiphenyl ● Aniline ● Anthracene ● Aramite ● alpha-BHC ● beta-BHC ● delta-BHC ● gamma-BHC ● Benzene ● Benz(a)anthracene ● Benzo(b)fluoranthene ● Benzo(k)fluoranthene ● Benzo(g,h,i)perylene ● Benzo(a)pyrene ● Bromodichloromethane ● Methyl bromide (bromomethane) ● 4-Bromophenyl phenyl ether ● n-Butyl alcohol ● Butyl benzyl phthalate ● 2-sec-Butyl-4-6-dinitrophenol (dinoseb) 	<ul style="list-style-type: none"> ● Carbon disulfide ● Carbon tetrachloride ● Chlordane (alpha and gamma isomers) ● p-Chloroaniline ● Chlorobenzene ● Chlorobenzilate ● 2-Chloro-1,3-butadiene ● Chlorodibromomethane ● Chloroethane ● bis(2-Chloro-ethoxy)methane ● bis(2-chloroethyl)ether ● Chloroform ● bis(2-Chloroisopropyl)ether ● p-Chloro-m-cresol ● Chloromethane (methylene chloride) ● 2-Chloro-naphthalene ● 2-Chlorophenol ● 3-Chloropropylene ● Chrysene ● o-Cresol ● m-Cresol ● p-Cresol ● Cyclohexanone ● 1,2-Dibromo-3-chloropropane ● Ethylene dibromide ● Dibromomethane ● 2,4-D ● o,p'-DDD ● p,p'-DDD ● o,p'-DDE

TABLE 5-1

Basis for Listing Hazardous Waste
 40 CFR 261, Appendix VII
 Shell Oil Company
 Deer Park, Texas

F039	F039 (continued)
<ul style="list-style-type: none"> ● p,p'-DDE ● o,p'-DDT ● p,p'-DDT ● Dibenz(a,h)anthracene ● Dibenz(a,e)pyrene ● m-Dichlorobenzene ● o-Dichlorobenzene ● p-Dichlorobenzene ● Dichlorodifluoromethane ● 1,1-Dichloroethane ● 1,2-Dichloroethane ● 1,1-Dichloroethylene ● trans-1,2-Dichloroethylene ● 2,4-Dichlorophenol ● 2,6-Dichlorophenol ● 1,2-Dichloropropane ● cis-1,3-Dichloropropylene ● trans-1,3-Dichloropropylene ● Dieldrin ● Diethyl phthalate ● 2,4-Dimethyl phenol ● Dimethyl phthalate ● Di-n-butyl phthalate ● 1,4-Dinitrobenzene ● 4,6-Dinitro-o-cresol ● 2,4-Dinitrophenol ● 2,4-Dinitrotoluene ● 2,6-Dinitrotoluene ● Di-n-octyl phthalate 	<ul style="list-style-type: none"> ● Di-n-propylnitrosamine ● 1,4-Dioxane ● Diphenylamine ● Diphenylnitrosamine ● 1,2-Diphenylhydrazine ● Disulfoton ● Endosulfan I ● Endosulfan II ● Endosulfan sulfate ● Endrin ● Endrin aldehyde ● Ethyl acetate ● Ethyl cyanide (propanenitrile) ● Ethyl ether ● bis(2-Ethylhexyl)phthalate ● Ethyl methacrylate ● Ethylene oxide ● Famphur ● Fluoranthene ● Fluorene ● Heptachlor ● Heptachlor epoxide ● Hexachlorobenzene ● Hexachlorobutadiene ● Hexachlorocyclopentadiene ● HxCDDs (all dioxins) ● HxCDF (all furans) ● Hexachloroethane ● Hexachloropropylene

TABLE 5-1

Basis for Listing Hazardous Waste
 40 CFR 261, Appendix VII
 Shell Oil Company
 Deer Park, Texas

F039	F039 (continued)
<ul style="list-style-type: none"> ● Indeno (1,2,3-c,d)pyrene ● Iodomethane ● Isobutyl alcohol ● Isodrin ● Isosafrole ● Kepone ● Methacrylonitrile ● Methanol ● Methapyrilene ● Methoxychlor ● 3-Methylcholanthrene ● 4,4-Methylene bis(2-chloroaniline) ● Methyl ethyl ketone ● Methyl isobutyl ketone ● Methyl methacrylate ● Methyl methansulfonate ● Methyl parathion ● Naphthalene ● 2-Naphthylamine ● p-Nitroaniline ● Nitrobenzene ● 5-Nitro-o-toluidine ● p-Nitrophenol ● N-Nitrosodiethylamine ● N-Nitrosodimethylamine ● N-Nitroso-di-n-butylamine ● N-Nitrosomethylethylamine ● N-Nitrosomorpholine ● N-Nitrosopiperidine 	<ul style="list-style-type: none"> ● N-Nitrosopyrrolidine ● Parathion ● Total PCBs ● Pentachlorobenzene ● PeCDDs ● PeCDFs ● Pentachloronitrobenzene ● Pentachlorophenol ● Phenacetin ● Phenanthrene ● Phenol ● Phorate ● Phthalic anhydride ● Pronamide ● Pyrene ● Pyridine ● Safrole ● Silvex (2,4,5-TP) ● 2,4,5-T ● 1,2,4,5-Tetrachlorobenzene ● TCDDs ● TCDFs ● 1,1,1,2-Tetrachloroethane ● 1,1,2,2-Tetrachloroethane ● Tetrachloroethylene ● 2,3,4,6-Tetrachlorophenol ● Toluene ● Toxaphene ● Tribromomethane (bromoform)

TABLE 5-1

Basis for Listing Hazardous Waste
 40 CFR 261, Appendix VII
 Shell Oil Company
 Deer Park, Texas

F039	F039 (continued)
<ul style="list-style-type: none"> ● 1,2,4-Trichlorobenzene ● 1,1,1-Trichloroethane ● 1,1,2-Trichloroethane ● Trichloroethylene ● Trichloromonofluoromethane ● 2,4,5-Trichlorophenol ● 2,4,6-Trichlorophenol ● 1,2,3-Trichloropropane ● 1,1,2-Trichloro-1,2,2-trifluoroethane ● tris(2,3-Dibromopropyl)phosphate ● Vinyl chloride ● Xylenes (sum of o,m,p isomers) 	<ul style="list-style-type: none"> ● Antimony ● Arsenic ● Barium ● Beryllium ● Cadmium ● Chromium (total) ● Cyanides (total) ● Cyanides (amenable) ● Fluoride ● Lead ● Mercury ● Nickel ● Selenium ● Silver ● Sulfide ● Thallium ● Vanadium

Notes: For F039 wastes, the basis of listing is "all constituents for which treatment standards are specified for multi-source leachate under 40CFR 268.43(a), Table CCW".

Because the waste stream is a liquid, no TCLP extraction/analyses were necessary. All analyses were performed on a total basis.

Table 5-2 shows the analytical program for characterizing the MTR Landfill Leachate in 2002. All analytical methods are from EPA SW-846 Test Methods for Evaluating Solid Waste-Physical and Chemical Methods.

TABLE 5-2

Target Compounds for Waste Characterization
 Shell Oil Company
 Deer Park, Texas

Constituents	EPA Method (a)
<i>Appendix IX Analyses</i>	
• Volatiles	8260B
• Semivolatiles (including PCBs, Pesticides, Herbicides)	8270C
• Metals (b)	6010 for all but the following metals • 7470A mercury • 6020 arsenic • 6020 lead • 6020 selenium
• Herbicides (chlorinated)	8151A
• Pesticides (chlorinated and organophosphorus)	8081A/8141A
• PCBs	8082
• Dioxins/Furans	1613B
<i>Hazardous Waste Characteristics/Other</i>	
<i>Ignitability</i>	1010
<i>pH</i>	150.1
<i>Reactive Sulfide</i> (not required per EPA Pre-Petition Delisting Meeting)	Not required
<i>Reactive Cyanide</i> (not required per EPA Pre-Petition Delisting Meeting)	Not required
<i>Total Cyanide</i>	9012A
<i>Total Sulfide</i>	376.1
<i>Total Oil and Grease</i>	1664
<i>Flouride</i>	300
<i>Methanol</i>	8000

NOTES:

- (a) Test Methods for Evaluating Solid Waste-Physical and Chemical Methods, EPA SW-846. Methods for Chemical Analysis of Water and Wastes, EPA-600/4-79-020.
- (b) Appendix IX Metals were run on samples with pH adjustments to pH2, pH7 and pH9 on one of the four samples collected. (per EPA Pre-Petition Delisting Meeting).

6.0 WASTE SAMPLING INFORMATION

6.1 SAMPLING PERSONNEL INFORMATION

The landfill leachate was sampled by the following contractor:

Mr. Stephen Roach
On Site Hazardous Waste Coordinator
ONYX-Environmental Services
1800 S. Highway 146
Baytown, Texas 77520

6.2 SAMPLING STRATEGY

Sampling was conducted in accordance with a written sampling plan (dated April 10, 2002) and approved by the EPA in a letter dated May 31, 2002. Sample integrity was assured by following standard sample handling, preservation, documentation and custody procedures (see Sections 6.4 through 6.7). A total of eight samples and one duplicate were collected for characterization.

6.3 SAMPLE COLLECTION AND IDENTIFICATION

Four samples of the primary leachate and four samples of the secondary leachate were collected for characterization from June 2002 through October 2002. The sampling procedures in the Sampling and Analysis plan were modified to incorporate EPA's comments to sample and characterize the primary and secondary leachate separately (site visit May 2, 2002). Procedures were followed and documented to show that each leachate collection tank had a complete turnover between each sampling event. **Table C-1** in Appendix C documents the volume of leachate removed from each tank prior to each sampling event. This procedure ensured that four separate samples of leachate were collected from each tank rather than multiple samples from one tank volume of leachate.

6.3.1 Initial Sample

The valve to tank T-323 (primary leachate) was opened by the operator and about 1-liter of leachate was purged and added back to the tank. The sample was then collected directly into the sample bottles from the sample port. The sample for volatile analyses was collected first by slowly filling two 40-mL VOA vials with little to no turbulence. There was no headspace in the VOA vials when filled. The remaining bottles were then filled from the sample port. For metals analysis, the sample was collected into three bottles containing no preservative.

Instructions were added to the chain-of-custody form for the laboratory to adjust the pH to 2, 7 and 9 upon receipt. The date and time of collection was noted on each bottle and in the field notebook. The sample I.D. was T323-1. This procedure was repeated with tank T-324 (secondary leachate) except the sample I.D. was T324-1

6.3.2 Second Sample

Prior to collecting a second sample from the leachate tanks, at least one tank volume (per tank) was removed for disposal off site. The volume of leachate removed from each tank was documented. These log sheets are with the laboratory analytical reports in Appendix C to this petition. The samples were collected following the same procedures described above except that only one bottle for metals was filled for each sample. The bottle for metals contained preservative to adjust the sample pH to less than 2.0. The sample I.D.s were T323-2 and T324-2. The dates and times of sample collection were noted on the labels, field notebook and volume log form.

6.3.3 Third Sample and Duplicate

The third sampling event was conducted following the above procedures. The sample I.D.s were T323-3 and T323-4. The date and time of collection was noted on the sample labels, logbook and volume log form.

6.3.4 Fourth Sample

The fourth sampling event was conducted following the procedures in Section 6.3.2. A duplicate sample was collected from tank T-324 for QA/QC analysis. The fourth sample I.D.s were T323-4, T324-4A and T324-4B. The dates and times of sample collection were noted on the labels, field notebook and volume log form.

Resample Event

Due to anomalous readings for nickel in the fourth primary sample and methanol in the fourth secondary sample, a resample event was conducted on December 23, 2002. These samples I.D.s were **Primary** and **Secondary**. The dates and times of sample collection were noted on the labels, field notebook and volume log form.

6.4 SAMPLE PRESERVATION AND HANDLING

All samples were placed in clean containers provided by the laboratory. Sample preservatives were provided in the sample containers by the analytical laboratory. **Table 6-1** shows the containers, preservation, and EPA holding times for the samples. Once the

TABLE 6-1

Sample Containers, Preservation and Holding Times
Shell Oil Company
Deer Park, Texas

Analysis	Sample Size/Container (Plastic/Glass)	Preservation	Holding Time
Appendix IX Volatiles	2 x 40 ml glass vials	Cool to 4°C HCl to pH < 2	14 days
Appendix IX Semivolatiles	2 x 1,000 ml glass	Cool to 4°C Na ₂ S ₂ O ₃	7/40 (a)
Appendix IX Pesticides/Herbicides PCBs	4 x 1,000 ml glass	Cool to 4°C	7/40 (a)
Ignitability	1 x 500 ml plastic/glass	Cool to 4°C	28 days
pH	50 ml/plastic or glass	Cool to 4°C	Analyze immediately
Oil and Grease	1 x 1,000 ml glass	H ₂ SO ₄ to pH < 2	28 days
Total Sulfide	1 x 500 ml glass/plastic	Cool to 4°C Zinc acetate, NaOH to pH > 9	7 days
Total Cyanide	1 x 1000 ml glass/plastic	Cool to 4°C Ascorbic acid, NaOH to pH > 12	14 days
Appendix IX Metals	500 ml/plastic or glass	HNO ₃ to pH < 2	6 months except mercury (28 days)
for pH7 and pH9 (initial sample only)	(2) 500 ml/plastic or glass	No preservative (b)	same as above
Appendix IX Dioxins/Furans	2 x 1,000 ml/glass	Cool to 4°C	40 days/40 days

NOTES:

- (a) 7/40 = Extract within 7 days of collection, analyze within 40 days of extraction.
- (b) Request on chain-of-custody form that sample pH be adjusted in the lab to pH 7 and pH 9.

samples were collected, they were secured in an ice chest with a completed chain-of-custody form. The cooler were sealed with tape and was picked up by the laboratory.

6.5 SAMPLING DOCUMENTATION

To prevent misidentification of samples, labels were attached to each sample container. The labels were water proof and legible contained the following information:

- Sample identification number
- Date and time of collection
- Sample description
- Name of sampler
- Analysis to be performed

A bound field notebook was maintained to provide daily records of significant events, observations, and measurements. All entries were made using a pen or indelible marker. The field notebook documented the following:

- Date and time of sampling event
- Name of sample collector
- Process sampled
- Description of waste
- Sample location
- Sampling method
- Number, volume, and appearance of sample
- Sample preservation
- Any field measurements made
- Field observations

6.6 SAMPLE CUSTODY

Chain-of-custody procedures were used to trace possession and handling of individual samples from the time of collection in the field through receipt by the independent analytical laboratory.

Each time a batch of samples was prepared for pickup by the laboratory, a chain-of-custody record was completed and accompanied the shipment. Whenever custody of the samples was transferred, the individual relinquishing and the individual receiving the samples signed, dated, and noted the time on the form. The original form accompanied the shipment to the laboratory and was returned to the Project Manager with the analytical laboratory reports.

If a delivery or courier service was used to transport the samples, the bill of lading or receipt from the independent service was maintained by the Project Manager to document custody for that segment of the sample transport.

6.7 QUALITY ASSURANCE/QUALITY CONTROL PROCEDURES

Each of the samples analyzed was subjected to extensive quality control. Quality control procedures in the field included sample handling and documentation protocols as described previously. Techniques were used in the field to avoid sample contamination and to adequately preserve each sample until it reached the laboratory. There was no sampling equipment associated with tank sampling, as samples were collected directly into the sample containers. Decontamination of equipment was not necessary (equipment rinsate samples were not necessary).

Sampling personnel wore disposal nitrile gloves to reduce the possibility of cross contamination. Sample bottles were laboratory-precleaned containers that met cleaning QC requirements.

Trip blanks, consisting of laboratory grade deionized water were supplied by the laboratory. These blanks were carried with the sample containers during the first week and last week of sample collection. The Trip Blanks were analyzed for Appendix IX VOA analyses. The purpose of the trip blanks was to determine the impact, if any, of ambient VOC concentrations in the refinery and laboratory during sampling and analysis.

Additional quality control procedures were employed in the laboratory. As a minimum, laboratory QA/QC procedures were in accordance with the guidelines in Volume One, Chapter One of EPA document SW-846. Laboratory QA/QC samples included method blank analyses, surrogate spikes and calibration curves. A discussion of the laboratory and field QA/QC data is presented in the Quality Assurance Report in **Appendix A** to this Delisting Petition.

6.8 STATEMENT OF REPRESENTATIVENESS OF SAMPLES

Based on the sampling strategy discussed in Section 6.2 (and in the SAP) and the use of EPA approved methods to collect, analyze and maintain proper documentation and custody of the samples, the samples of primary and secondary landfill leachate collected in 2002 are considered representative of the petitioned waste stream. There were no deviations from the SAP dated April 10, 2002 and revised May 15, 2002 during the June 2002-December 2002 sampling events (except the duplicate was collected from Round 4 instead of Round 3).

7.0 WASTE ANALYSIS INFORMATION

7.1 ANALYTICAL LABORATORY INFORMATION

The following laboratories were used for analysis of samples collected in support for this delisting petition:

Severn Trent Laboratories, Inc. (STL)
6310 Rothway Street
Houston, Texas 77045
Phone: (713) 690-4444

Alta Analytical Laboratory
5070 Robert J. Mathew Parkway
El Dorado Hills, California 95762
Phone: (916) 933-1640
* For analysis of Dioxin/Furans

Severn Trent Laboratories, Inc. (STL)
14046 Summit Drive
Austin, Texas 78728
(512) 244-0855
*For analysis of organophosphorous pesticides

STL Houston performed all analyses except those indicated with an asterisk (*). The professional qualifications for the individuals who performed the analyses of the waste samples are included in **Appendix D**.

The Quality Assurance Report in **Appendix A** contains information relating to the laboratory handling and analysis procedures employed for the waste samples. Included in **Appendix A** are the Sample I.D., laboratory I.D., sample preservation technique, sample collection dates and dates of sample extraction and analysis. The specific equipment used is coded to an equipment list in the Quality Assurance Report. A list of the analytical methods used for each of the analyses is also included in the Quality Assurance Report.

7.2 SUMMARY OF ANALYTICAL RESULTS

This section summarizes the results of analyses performed on samples collected from the petitioned waste stream from June 2002 through December 2002. A copy of the laboratory analytical reports are included as **Appendix C**.

7.2.1 Hazardous Waste Characteristics

A summary of the results of analyses for reactivity, ignitability and corrosivity is included in **Table 7-1**. As shown, none of the samples exhibit hazardous waste characteristics as defined by 40 CFR 261.22 and 261.23. **Table 7-2** and **Table 7-3** compare the concentrations of the TCLP constituents in the primary and secondary leachate, respectively, to the maximum TCLP levels found in 40 CFR 261.24. As shown, none of the constituents in the primary or secondary leachate exceed the maximum allowable TCLP concentrations and the landfill leachate is not hazardous due to the toxicity characteristic.

7.2.2 Appendix IX Analytes Detected on a Total Basis

Summaries of the constituents detected in the MTR Landfill Leachate, are presented in **Table 7-4** and **Table 7-5** for the primary and secondary leachate, respectively. Only those constituents detected above the limit of quantitation (LOQ) are shown for the volatile and semivolatile organics.

Volatile Organics

The volatile organic analyses were run on grab samples collected from the Primary Leachate Tank (T323) and from the Secondary Leachate Tank (T324). As shown very few volatiles were detected.

Semivolatile Organics, PCBs, Pesticide, Herbicides, and Dioxin/Furans

Tables 7-4 and **7-5** present a summary of the semivolatile constituents, pesticides, herbicides, PCBs and dioxin/furan results for the primary and secondary leachate samples. For the dioxin/furan results, EPA Region 6 recommends calculating a toxicity equivalent quotient (TEQ) for 2,3,7,8-tetrachlorodibenzo(p)dioxin (TCDD). The toxicity equivalent quotient is calculated by converting the 17 dioxin/furan congener concentrations to a 2,3,7,8-TCDD concentration using toxicity equivalent factors (TEFs). The TEFs for the 17 congeners are listed in EPA Region 6 Delisting Technical Support Document (8/31/02). The 2,3,7,8-TCDD equivalent calculation spreadsheets are in Appendix E for the sampling events. The calculated 2,3,7,8-TCDD values are shown in **Tables 7-4** and **7-5**. These values are compared to EPA's delisting value for this constituent.

Metals

A summary of the Appendix IX metals detected in the samples over the sampling period is shown in **Table 7-6** and **Table 7-7** for the primary and secondary leachate, respectively.

During the first week of sampling, three samples were collected for pH adjustment to pH2, pH 7 and pH9 prior to analysis for metals. This procedure was required by EPA to simulate leachate from a landfill. In accordance with the approved SAP this procedure was conducted on only one set of samples. A review of the data in **Tables 7-6** and **7-7** show that the pH variance did not appear to affect the concentration of the metals in the samples.

TABLE 7-1

Summary of Reactivity, Corrosivity, and Ignitability Analyses
MTR Landfill Leachate
Shell Oil Company
Deer Park, Texas

Sample ID	Date Collected	Concentration			
		Total Sulfide (mg/L)	Total Cyanide (µg/L)	pH (Std. Units)	Ignitability (Flashpoint) (Degrees F)
T323-1 Primary Leachate No. 1	6/11/2002	23	<10.0	7.80	>212
T324-1 Secondary Leachate No. 1	6/11/2002	<5.0	<10.0	7.64	>212
T323-2 Primary Leachate No. 2	8/1/02	50	<10.0	7.91	>212
T324-2 Secondary Leachate No. 2	9/4/02	19	<50	8.41	>212
T323-3 Primary Leachate No. 3	9/6/02	22	<10.0	NA	>212
T324-3 Secondary Leachate No. 3	10/14/02	6.8	<10.0	7.4	>212
T323-4 Primary Leachate No. 4	9/27/02	110	<10.0	7.5	>212
T324-4A Secondary Leachate No. 4	10/24/02	16	<10.0	7.53	>212
T324-4B (Dup) Secondary Leachate No. 4	10/24/02	15	<10.0	7.37	>212
Hazardous Waste Criteria (40 CFR 261.21-261.23)		>500 mg/kg	>250 mg/kg	≤2 or ≥12.5	<140°F

Notes:

<## = Not detected above the indicated laboratory Limit of Quantitation.

- (a) Oil and Grease concentrations ranged from <5.0 mg/L to 8.2 mg/L in T323 samples and from 5.0 mg/L to 230 mg/L in T324 samples.
- (b) Fluoride concentrations were <0.30 mg/L in T323 samples and ranged from <0.30 mg/L to 0.54 mg/L in T324 samples.

TABLE 7-2

Summary of Toxicity Characteristic Analyses
MTR Landfill Leachate – Primary (T-323)
Shell Oil Company
Deer Park, Texas

Contaminant	Regulatory Level (mg/L) (a)	T323-1 6/11/2002 (mg/L)	T323-2 8/1/2002 (mg/L)	T323-3 9/6/2002 (mg/L)	T323-4 9/27/2002 (mg/L)
Arsenic	5.0	<0.010	<i>0.0294</i>	0.0148	<0.05
Barium	100.0	0.119	<i>0.237</i>	0.108	0.072
Benzene	0.5	<0.005	<i>0.018</i>	<0.05	0.008
Cadmium	1.0	<0.005	<i><0.010</i>	<0.005	<0.005
Carbon tetrachloride	0.5	<0.005	<0.005	<i><0.05</i>	<0.005
Chlordane	0.03	<0.00005	<0.00005	<i><0.0001</i>	<0.00005
Chlorobenzene	100.0	<0.005	<0.005	<i><0.05</i>	<0.005
Chloroform	6.0	<0.005	<0.005	<i><0.05</i>	<0.005
Chromium	5.0	<0.010	<i>0.014</i>	<0.010	<0.010
o-Cresol	200.0	<i><0.010</i>	<0.0015	<0.0015	<0.0015
m-Cresol	200.0	<i><0.010</i>	<0.0015	<0.0015	<0.0015
p-Cresol	200.0	0.020	<i>0.028</i>	0.00184	0.0127
Cresol	200.0	0.020	<i>0.028</i>	0.00184	0.0127
2,4-D	10.0	<i><0.005</i>	<0.001	<0.001	<0.001
1,4-Dichlorobenzene	7.5	<i><0.010</i>	<0.002	<0.002	<0.002
1,2-Dichloroethane	0.5	<0.005	<0.005	<i><0.05</i>	<0.005
1,1-Dichloroethylene	0.7	<0.005	<0.005	<i><0.05</i>	<0.005
2,4-Dinitrotoluene	0.13	<i><0.010</i>	<0.0015	<0.0015	<0.015
Endrin	0.02	<0.0001	<0.0001	<i><0.0002</i>	<0.001
Heptachlor (and its Epoxide)	0.008	<0.00005	<0.00005	<i><0.0001</i>	<0.00005
Hexachlorobenzene	0.13	<i><0.010</i>	<0.0015	<0.0015	<0.0015
Hexachlorobutadiene	0.5	<i><0.010</i>	<0.002	<0.002	<0.002
Hexachloroethane	3.0	<i><0.010</i>	<0.002	<0.002	<0.002
Lead	5.0	<0.003	<0.010	<0.003	<i><0.015</i>
Lindane	0.4	<0.00005	<0.00005	<i><0.0001</i>	<0.00005
Mercury	0.2	<i><0.0002</i>	<0.0002	<0.0002	<0.0002
Methoxychlor	10.0	<0.0005	<0.0005	<i><0.001</i>	<0.0005
Methyl ethyl ketone	200.0	<0.010	<0.010	<i><0.100</i>	<0.010
Nitrobenzene	2.0	<i><0.010</i>	<0.0015	<0.0015	<0.0015
Pentachlorophenol	100.0	<i><0.050</i>	<0.0015	<0.0015	<0.0015
Pyridine	5.0	<i><0.010</i>	<0.004	<0.004	<0.004
Selenium	1.0	0.008	<i>0.0151</i>	0.0086	<0.025
Silver	5.0	<i><0.010</i>	<0.010	<0.010	<0.010
Tetrachloroethylene	0.7	<0.005	<0.005	<i><0.05</i>	<0.005
Toxaphene	0.5	<0.005	<0.005	<i><0.010</i>	<0.005
Trichloroethylene	0.5	<0.005	<0.005	<i><0.05</i>	<0.005
2,4,5-Trichlorophenol	400.0	<i><0.010</i>	<0.002	<0.002	<0.002
2,4,6-Trichloroprophenol	2.0	<i><0.010</i>	<0.002	<0.002	<0.002
2,4,5-TP (Silvex)	1.0	<i><0.005</i>	<0.001	<0.001	<0.001
Vinyl Chloride	0.2	<0.010	<0.010	<0.100	<i><0.010</i>

Notes:

- (a) Maximum concentration of constituents for the Toxicity Characteristic 40 CFR 261.24 Table 1.
(b) The maximum concentration is shown in **bold and italics**.

TABLE 7-3

Summary of Toxicity Characteristic Analyses
MTR Landfill Leachate – Secondary (T-324)
Shell Oil Company
Deer Park, Texas

Contaminant	Regulatory Level (mg/L) (a)	T324-1 6/11/2002 (mg/L)	T324-2 9/4/2002 (mg/L)	T324-3 10/14/2002 (mg/L)	T324-4A 10/24/2002 (mg/L)	T324-4B (Dup) 10/24/2002 (mg/L)
Arsenic	5.0	<0.010	<0.010	<0.010	<0.010	<0.010
Barium	100.0	0.10	0.114	0.199	0.313	0.326
Benzene	0.5	<0.005	0.006	0.014	<0.005	<0.005
Cadmium	1.0	<0.005	<0.005	<0.005	<0.005	<0.005
Carbon tetrachloride	0.5	<0.005	<0.005	<0.005	<0.005	<0.005
Chlordane	0.03	<0.00005	<0.00005	<0.00005	<0.00005	<0.00005
Chlorobenzene	100.0	<0.005	<0.005	<0.005	<0.005	<0.005
Chloroform	6.0	<0.005	<0.005	<0.005	<0.005	<0.005
Chromium	5.0	<0.010	<0.010	<0.010	<0.010	<0.010
o-Cresol	200.0	<0.010	<0.0075	<0.0015	<0.0015	<0.0015
m-Cresol	200.0	<0.010	<0.0075	<0.0015	<0.0015	<0.0015
p-Cresol	200.0	<0.010	<0.0075	<0.0015	<0.0015	0.00414
Cresol	200.0	<0.010	<0.0075	<0.0015	<0.0015	0.00414
2,4-D	10.0	<0.001	<0.001	<0.001	<0.001	<0.001
1,4-Dichlorobenzene	7.5	<0.010	<0.010	<0.002	<0.002	<0.002
1,2-Dichloroethane	0.5	<0.005	<0.005	0.014	0.017	0.018
1,1-Dichloroethylene	0.7	<0.005	<0.005	<0.005	<0.005	<0.005
2,4-Dinitrotoluene	0.13	<0.010	<0.0075	<0.0015	<0.0015	<0.0015
Endrin	0.02	<0.00001	<0.00001	<0.00001	<0.00001	<0.00001
Heptachlor (and its Epoxide)	0.008	<0.00005	<0.00005	<0.00005	<0.00005	<0.00005
Hexachlorobenzene	0.13	<0.010	<0.0075	<0.0015	<0.0015	<0.0015
Hexachlorobutadiene	0.5	<0.010	<0.010	<0.002	<0.002	<0.002
Hexachloroethane	3.0	<0.010	<0.010	<0.002	<0.002	<0.002
Lead	5.0	<0.003	<0.003	0.0083	<0.003	<0.003
Lindane	0.4	<0.00005	<0.00005	<0.00005	<0.00005	<0.00005
Mercury	0.2	<0.0002	<0.0002	<0.0002	<0.0002	<0.0002
Methoxychlor	10.0	<0.0005	<0.0005	<0.0005	<0.0005	<0.0005
Methyl ethyl ketone	200.0	<0.010	<0.010	<0.010	<0.010	<0.010
Nitrobenzene	2.0	<0.010	<0.0075	<0.0015	<0.0015	<0.0015
Pentachlorophenol	100.0	<0.050	<0.0075	<0.0015	<0.0015	<0.0015
Pyridine	5.0	<0.010	<0.020	<0.004	<0.004	<0.004
Selenium	1.0	0.0078	<0.005	0.0053	<0.005	<0.005
Silver	5.0	<0.010	<0.010	<0.010	<0.010	<0.010
Tetrachloroethylene	0.7	<0.005	<0.005	<0.005	<0.005	<0.005
Toxaphene	0.5	<0.005	<0.005	<0.005	<0.005	<0.005
Trichloroethylene	0.5	<0.005	<0.005	<0.005	<0.005	<0.005
2,4,5-Trichlorophenol	400.0	<0.010	<0.010	<0.002	<0.002	<0.002
2,4,6-Trichlorophenol	2.0	<0.010	<0.010	<0.002	<0.002	<0.002
2,4,5-TP (Silvex)	1.0	<0.001	<0.001	<0.001	<0.001	<0.001
Vinyl Chloride	0.2	<0.010	<0.010	<0.010	<0.010	<0.010

Notes:

- (a) Maximum concentration of constituents for the Toxicity Characteristic 40 CFR 261.24 Table 1.
- (b) The maximum concentration is shown in **bold and italics**.

TABLE 7-4

Summary of Appendix IX Organic Constituents Detected
MTR Landfill Leachate – Primary (T-323)
Shell Oil Company
Deer Park, Texas

Sample ID:	T323-1	T323-2	T323-3	T323-4
Units:	(mg/L)	(mg/L)	(mg/L)	(mg/L)
Sample Collected:	(6/11/2002)	(8/1/2002)	(9/6/2002)	(9/27/2002)
<i>Appendix IX Volatiles</i>				
Acetone	0.030	0.030	<0.100	0.020
Benzene	<0.005	0.018	<0.050	0.008
Toluene	<0.005	0.600	<0.050	<0.005
Methanol	<2.5	<2.5	<2.5	<2.5
<i>Appendix IX Semivolatiles</i>				
4-Methylphenol (p-cresol)	0.020	0.028	0.00184	0.013
Naphthalene	<0.010	0.0317	<0.002	<0.002
2,4-Dimethyl phenol	<0.010	0.0041	<0.0015	0.0019
Phenol	<0.010	0.0352	0.0081	0.015
Acetophenone	<0.010	<0.0015	0.00303	0.0016
Phenanthrene	<0.010	<0.0015	<0.0015	0.0052
Fluorene	<0.010	<0.0015	<0.0015	0.00165
Bis (2-ethylhexyl)phthalate	<0.010	<0.0015	<0.0015	0.0037
<i>Appendix IX Organochlorine Pesticides (all non detects)</i>				
Aldrin	<0.00005	<0.00005	<0.0001	<0.00005
alpha-BHC	<0.00005	<0.00005	<0.0001	<0.00005
beta-BHC	<0.00005	<0.00005	<0.0001	<0.00005
gamma-BHC (Lindane)	<0.00005	<0.00005	<0.0001	<0.00005
delta-BHC	<0.00005	<0.00005	<0.0001	<0.00005
Chlordane	<0.00005	<0.00005	<0.0001	<0.00005
alpha-Chlordane	<0.00005	<0.00005	<0.0001	<0.00005
gamma-Chlordane	<0.00005	<0.00005	<0.0001	<0.00005
4,4'-DDD	<0.0001	<0.0001	N/A	<0.0001
4,4'-DDE	<0.0001	<0.0001	N/A	<0.0001
4,4'-DDT	<0.0001	<0.0001	N/A	<0.0001
Dieldrin	<0.0001	<0.0001	<0.0002	<0.0001
Endosulfan I	<0.00005	<0.00005	<0.0001	<0.00005
Endosulfan II	<0.0001	<0.0001	<0.0002	<0.0001
Endosulfan sulfate	<0.0001	<0.0001	<0.0002	<0.0001

Table 7-4
(continued)

Sample ID: Units:	T323-1 (mg/L)	T323-2 (mg/L)	T323-3 (mg/L)	T323-4 (mg/L)
Sample Collected:	(6/11/2002)	(8/1/2002)	(9/6/2002)	(9/27/2002)
Endrin	<0.0001	<0.0001	<0.0002	<0.0001
Endrin aldehyde	<0.0001	<0.0001	<0.0002	<0.0001
Heptachlor	<0.00005	<0.00005	<0.0001	<0.00005
Heptachlor epoxide	<0.00005	<0.00005	<0.0001	<0.00005
Methoxychlor	<0.0005	<0.0005	<0.001	<0.0005
Toxaphene	<0.005	<0.005	<0.010	<0.005
Kepone	<0.0025	<0.0025	<0.005	<0.0025
<i>Appendix IX Organophosphorus Pesticides (all non detects)</i>				
Disulfoton	N/A	<0.0002	<0.0019	<0.0002
Phorate	N/A	<0.0002	<0.0019	<0.0002
Dimethoate	N/A	<0.0002	<0.0019	<0.0002
Methyl parathion	N/A	<0.0002	<0.0019	<0.0002
Ethyl parathion	N/A	<0.0002	<0.0019	<0.0002
Famphor	N/A	<0.0002	<0.0019	<0.0002
Sulfotepp	N/A	<0.0002	<0.0019	<0.0002
O,O,O-Triethylphosphorothioate	N/A	<0.0002	<0.0019	<0.0002
<i>Appendix IV Herbicides (all non detects)</i>				
2,4-D	<0.005	<0.001	<0.001	<0.001
2,4,5-TP	<0.005	<0.001	<0.001	<0.001
2,4,5-T	<0.005	<0.001	<0.001	<0.001
<i>Appendix IX PCBs (all non detects)</i>				
Arochlor 1016	<0.001	<0.00095	<0.001	<0.001
Arochlor 1221	<0.001	<0.00095	<0.001	<0.001
Arochlor 1232	<0.001	<0.00095	<0.001	<0.001
Arochlor 1242	<0.001	<0.00095	<0.001	<0.001
Arochlor 1248	<0.001	<0.00095	<0.001	<0.001
Arochlor 1254	<0.001	<0.00095	<0.001	<0.001
Arochlor 1260	<0.001	<0.00095	<0.001	<0.001
<i>Appendix IX Dioxins/Furans</i>				
2,3,7,8-TCDD Equivalent	2.45E-09	2.13E-09	4.47E-09	3.24E-09

Notes:

<## = Not detected above the indicated LOQ.

Maximum concentrations shown in **bold and italic font**

TABLE 7-5

Summary of Appendix IX Organic Constituents Detected
MTR Landfill Leachate – Secondary (T-324)
Shell Oil Company
Deer Park, Texas

Sample ID: Units:	T324-1 (mg/L)	T324-2 (mg/L)	T324-3 (mg/L)	T324-4A (mg/L)	T324-4B (Dup) (mg/L)
Sample Collected:	(6/11/2002)	(9/4/2002)	(10/14/2002)	(10/24/2002)	(10/24/2002)
<i>Appendix IX Volatiles</i>					
Acetone	0.020 B	0.020	<0.010	0.070	0.090
Benzene	<0.005	0.006	0.014	<0.005	<0.005
Ethylbenzene	<0.005	0.005	<0.005	<0.005	<0.005
1,2-Dichloroethane	<0.005	<0.005	0.014	0.017	0.018
Xylenes	<0.015	0.033	<0.015	<0.015	<0.015
Methanol	<2.5	<2.5	<2.5	<2.5 (a)	4.8
<i>Appendix IX Semivolatiles</i>					
4-methylphenol (p-cresol)	<0.010	<0.0075	<0.0015	<0.0015	0.00414
Naphthalene	<0.010	0.0241	0.0125	<0.002	0.01173
2,4-Dimethylphenol	<0.010	0.0222	<0.0015	0.00166	<0.0015
Phenol	<0.010	<0.0075	0.0106	<0.0015	0.01177
Acetophenone	<0.010	<0.0075	<0.0015	0.00181	<0.0015
Phenanthrene	<0.010	0.0574	0.0051	<0.0015	0.00242
Fluorene	<0.010	0.0288	0.00246	<0.0015	0.00189
Bis(2-ethylhexyl)phthalate	<0.010	0.027	<0.0025	<0.0025	<0.0025
Acenaphthene	<0.010	0.024	0.00277	<0.0015	0.00244
<i>Appendix IX Organochlorine Pesticides</i>					
Aldrin	<0.00005	<0.00005	<0.00005	<0.00005	<0.00005
alpha-BHC	<0.00005	<0.00005	0.000576	0.000143	0.000219
beta-BHC	<0.00005	<0.00005	<0.00005	<0.00005	<0.00005
gamma-BHC (Lindane)	<0.00005	<0.00005	<0.00005	<0.00005	<0.00005
delta-BHC	<0.00005	<0.00005	0.000603	0.000076	0.000106
Chlordane	<0.00005	<0.00005	<0.00005	<0.00005	<0.00005
alpha-Chlordane	<0.00005	<0.00005	<0.00005	<0.00005	<0.00005
gamma-Chlordane	<0.00005	<0.00005	<0.00005	<0.00005	<0.00005
4,4'-DDD	<0.0001	0.0016	0.00024	<0.0001	0.00013
4,4'-DDE	<0.0001	<0.0001	<0.0001	<0.0001	<0.0001
4,4'-DDT	<0.0001	<0.0001	<0.0001	<0.0001	<0.0001
Dieldrin	<0.0001	<0.0001	<0.0001	<0.0001	<0.0001
Endosulfan I	<0.00005	<0.00005	<0.00005	<0.00005	<0.00005
Endosulfan II	<0.0001	<0.0001	<0.0001	<0.0001	<0.0001

Table 7-5
(Continued)

Sample ID: Units:	T324-1 (mg/L)	T324-2 (mg/L)	T324-3 (mg/L)	T324-4A (mg/L)	T324-4B (Dup) (mg/L)
Sample Collected:	(6/11/2002)	(9/4/2002)	(10/14/2002)	(10/24/2002)	(10/24/2002)
Endosulfan sulfate	<0.0001	<0.0001	<0.0001	<0.0001	<0.0001
Endrin	<0.0001	<0.0001	<0.0001	<0.0001	<0.0001
Endrin aldehyde	<0.0001	<0.0001	<0.0001	<0.0001	<0.0001
Heptachlor	<0.00005	<0.00005	<0.00005	<0.00005	<0.00005
Heptachlor epoxide	<0.00005	<0.00005	<0.00005	<0.00005	<0.00005
Methoxychlor	<0.0005	<0.0005	<0.0005	<0.0005	<0.0005
Toxaphene	<0.005	<0.005	<0.005	<0.005	<0.005
Kepon	<0.0025	<0.0025	<0.0025	<0.0025	<0.0025
<i>Appendix IX Organophosphorus Pesticides</i>					
Dimethoate	N/A	<0.0019	<0.0019	0.004	<0.002
Disulfoton	N/A	<0.0019	<0.0019	<0.002	<0.002
Famphur	N/A	<0.0019	<0.0019	<0.002	<0.002
Methyl parathion	N/A	<0.0019	<0.0019	<0.002	<0.002
Ethyl parathion	N/A	<0.0019	<0.0019	<0.002	<0.002
Phorate	N/A	<0.0019	<0.0019	<0.002	<0.002
Sulfotepp	N/A	<0.0019	<0.0019	<0.002	<0.002
O,O,O-Triethylphosphorothioate	N/A	<0.0019	<0.0019	<0.002	<0.002
<i>Appendix IX Herbicides (all non detects)</i>					
2,4-D	<0.001	<0.001	<0.001	<0.001	<0.001
2,4,5-TP	<0.001	<0.001	<0.001	<0.001	<0.001
2,4,5-T	<0.001	<0.001	<0.001	<0.001	<0.001
<i>Appendix IX PCBs (all non detects)</i>					
Arochlor 1016	<0.001	<0.001	<0.001	<0.001	<0.001
Arochlor 1221	<0.001	<0.001	<0.001	<0.001	<0.001
Arochlor 1232	<0.001	<0.001	<0.001	<0.001	<0.001
Arochlor 1242	<0.001	<0.001	<0.001	<0.001	<0.001
Arochlor 1248	<0.001	<0.001	<0.001	<0.001	<0.001
Arochlor 1254	<0.001	<0.001	<0.001	<0.001	<0.001
Arochlor 1260	<0.001	<0.001	<0.001	<0.001	<0.001
<i>Appendix IX Dioxins/Furans</i>					
2,3,7,8-TCDD Equivalent	3.79E-09	9.40E-09	7.05E-09	3.67E-09	3.66E-09

Notes:

<## = Not detected above the indicated LOQ.

Maximum concentrations shown in **bold and italic font**

(a) The original value was 7.6 mg/L. The MS/MSD samples showed high percent recoveries indicating this value may be biased high. The data shown is for a resample collected December 23, 2002 per EPA's consent.

(b) B = detected in blank. Sample concentration less than five times the blank concentration.

TABLE 7-6

Summary of Appendix IX Metals Results
MTR Landfill Leachate – Primary (T-323)
Shell Oil Company
Deer Park, Texas

Sample ID: Units:	Primary Leachate Tank (T-323)					
	T323-1 pH 2 (mg/L)	T323-1 pH 7 (mg/L)	T323-1 pH 9 (mg/L)	T323-2 (mg/L)	T323-3 (mg/L)	T323-4 (mg/L)
Sample Collected:	6/11/02	6/11/02	6/11/02	8/1/02	9/6/02	9/27/02
<i>Appendix IX Metals</i>						
Antimony	<0.05	<0.05	<0.05	<0.05	<0.05	<0.05
Arsenic	<0.010	<0.010	<0.010	0.0295	0.0148	<0.05
Barium	0.119	0.120	0.025	0.237	0.108	0.072
Beryllium	<0.005	<0.005	<0.005	<0.010	<0.005	<0.005
Cadmium	<0.005	<0.005	<0.005	<0.010	<0.005	<0.005
Chromium	<0.010	<0.010	<0.010	0.014	<0.010	<0.010
Cobalt	<0.010	<0.010	<0.010	NA	<0.010	0.016
Copper	<0.010	<0.010	<0.010	NA	0.025 B	0.022 B
Lead	<0.003	<0.003	<0.003	<0.010	<0.003	<0.015
Mercury	<0.0002	<0.0002	<0.0002	<0.0002	<0.0002	<0.0002
Nickel	0.116	0.112	0.130	0.285	0.00693	0.906 (a)
Selenium	0.008	0.0082	0.0076	0.015	0.0086	<0.025
Silver	<0.01	<0.01	<0.01	NA	<0.01	<0.01
Tin	<0.02	<0.02	<0.02	NA	<0.02	<0.02
Thallium	<0.030	<0.030	<0.030	<0.003	<0.003	<0.03
Vanadium	0.036	0.034	0.041	0.113	0.063	0.046

Notes:

<## = Not detected above the indicated LOQ.

Maximum concentrations shown in **bold and italic font**.

- (a) The original value was 2.86 mg/L. Nickel was also detected in the method blank. Due to the anomalous high nickel value, a resample was collected on December 23, 2002 per EPA's consent. The data shown is for the resample.
- (b) B = detected in blank. Sample concentration less than five times the blank concentration.

TABLE 7-7

Summary of Appendix IX Metals Results
MTR Landfill Leachate – Secondary (T-324)
Shell Oil Company
Deer Park, Texas

Sample ID: Units:	Secondary Leachate Tank (T-324)						
	T324-1 pH 2 (mg/L)	T324-1 pH 7 (mg/L)	T324-1 pH 9 (mg/L)	T324-2 (mg/L)	T324-3 (mg/L)	T324-4A (mg/L)	T324-4B Dup (mg/L)
Sample Collected:	6/11/2002	6/11/2002	6/11/2002	9/3/2002	(10/14/02)	(10/24/02)	(10/24/02)
<i>Appendix IX Metals</i>							
Antimony	<0.050	<0.05	<0.05	<0.05	<0.05	<0.05	<0.05
Arsenic	<0.10	<0.010	<0.010	<0.010	<0.010	<0.010	<0.010
Barium	0.010	0.097	0.040	0.114	0.199	0.313	0.326
Beryllium	<0.005	<0.005	<0.005	<0.005	<0.005	<0.005	<0.005
Cadmium	<0.005	<0.005	<0.005	<0.005	<0.005	<0.005	<0.005
Chromium	<0.010	<0.010	<0.010	<0.010	<0.010	<0.01	<0.01
Cobalt	0.032	0.052	<0.037	<0.010	0.043	<0.01	<0.01
Copper	<0.010	<0.010	<0.010	<0.010	0.082	0.014	0.011
Lead	<0.003	<0.003	<0.003	<0.003	0.0083	<0.003	<0.003
Mercury	<0.0002	<0.0002	<0.0002	<0.0002	<0.0002	<0.0002	<0.0002
Nickel	0.113	0.118	0.117	0.055	0.414	0.095	0.080
Selenium	0.0078	0.0083	0.0081	<0.005	0.0053	<0.005	<0.005
Silver	<0.010	<0.010	<0.010	<0.010	<0.010	<0.010	<0.010
Thallium	<0.030	<0.030	<0.030	<0.030	<0.030	<0.030	<0.030
Tin	<0.020	<0.020	<0.020	<0.020	<0.020	<0.020	<0.020
Vanadium	0.031	0.032	0.033	0.038	0.130	0.040	0.030

Notes:

<## = Not detected above the indicated LOQ.

Maximum concentrations shown in **bold and italic font**.

8.0 DATA EVALUATION USING EPA DRAS

In accordance with EPA Region 6 requirements the analytical data for the samples were input into the Delisting Risk Assessment Software (DRAS), Version 2.0 for evaluation. This software program provides a scientifically defensible means to evaluate whether a RCRA listed waste qualifies for delisting under 40 CFR §260.20 and 260.22 with regard to toxicity. The program calculates carcinogenic and non-cancer risks associated with disposal of a petitioned waste to a landfill or surface impoundment. For the Shell Oil evaluation, a surface impoundment scenario was used since the *Landfill Leachate* will be treated in an impoundment, once delisted. The methods used to calculate chemical concentrations in media at the point of exposure are based on EPA's fate and transport mechanisms. The methods used to determine risk associated with the waste disposal scenarios evaluated for delisting a petitioned waste are based on EPA's risk assessment algorithms.

8.1 INPUT VALUES

In accordance with the EPA RCRA Delisting Technical Support Document, the following waste specific information was entered for the DRAS evaluation for both the primary and secondary leachate:

- waste volume: 14,000 tons/yr = 16,619 cy/yr (See Section 3.3)
- waste management unit: surface impoundment
- maximum concentration of VOAs detected (Table 7-4, primary and Table 7-5, secondary)
- maximum concentration of semivolatiles, pesticides, herbicides, PCBs, dioxins detected (Table 7-4, primary and Table 7-5, secondary)
- maximum concentration of metals detected (Table 7-6, primary and Table 7-7, secondary)
- acceptable cancer risk of 10^{-5}
- acceptable hazard index of 0.1
- multi-year delisting (default of 20 years)

The concentration data were entered as a "total" basis and TCLP basis since the waste streams are aqueous. Per EPA Region 6 instructions, the detection limit was entered for those constituents reported as below the detection limits. A separate DRAS run was performed for the primary and secondary leachate. The output files from the DRAS runs are presented in Appendix F and discussed below.

APPENDIX A
Quality Assurance Report



01020873

HERITAGE ENVIRONMENTAL SERVICES, LLC.

COMMERCIAL LABORATORY OPERATIONS

7901 West Morris Street Indianapolis IN 46231

www.heritage-enviro.com (800)827-4374 Fax: (317) 486-5095

I - 61659

Customer name/number: <u>WEAVER BOYS</u>		Submitter #		Analyses Requested (Note special detection limits or methods)				Send Report To:			
Project Name: <u>DAVIS JUNCTION</u>		Z Quote No: <u>Z 151505</u> (Given to you by your contact)		Sample type (Matrix): <u>Other</u> DW, GW, WW, Soil, Oil, Sludge, Swipe Number of Containers: <u>2</u> <u>Z 151505</u>				Co:			
PO No. or Project/Activity ID: <u>0120-4A-30</u>		PRINT HERITAGE TSR NAME: <u>CHRIS BOYLE / STUART KINNAMON</u>						Add:			
CUSTOMER STATUS: New / <input checked="" type="checkbox"/> Existing If no previous credit has been established with Heritage, prepayment (check, VISA, etc) is required at the time of sample submittal to the laboratory.		Sampled By: <u>ROBERT SHERBUSKI</u> <i>[Signature]</i>						Attrn:		Phone: () Yes	
Standard: _____ Rush Date _____ / _____ / _____ Mo Day Yr (Accelerated TAT subject to Additional Charge) (Date must be Accepted and Approved by Lab)		Date Sampled: <u>5/22/08</u> Time sampled: <u>1300</u> AM/PM: <u>AM</u>						Sample ID and/or Location where your sample was taken: <u>PHASE I</u>		Fax: () E-mail:	
Sample ID and/or Location where your sample was taken: <u>PHASE I</u>		Sample type (Matrix): <u>Other</u> DW, GW, WW, Soil, Oil, Sludge, Swipe		Number of Containers: <u>2</u>		Sample Turn Around Time		Remarks:			
Date Sampled: <u>5/22/08</u> Time sampled: <u>1300</u> AM/PM: <u>AM</u>		Sample ID and/or Location where your sample was taken: <u>PHASE I</u>		Sample type (Matrix): <u>Other</u> DW, GW, WW, Soil, Oil, Sludge, Swipe		Number of Containers: <u>2</u>		Lab use only Sample No.: <u>A81980</u>			
Relinquished by: (Signature) <i>[Signature]</i> Date/Time: <u>5/22/08 1600</u>		Received by: (Signature) _____		Laboratory use only		Yes No		Comments:			
Relinquished by: (Signature) _____ Date/Time: <u>1</u>		Received by: (Signature) _____		Custody seals present/intact? <input checked="" type="checkbox"/>		Broken containers? <input checked="" type="checkbox"/>		COC agree with sample labels? <input checked="" type="checkbox"/>			
Relinquished by: (Signature) _____ Date/Time: <u>1</u>		Received by: (Signature) _____		Correct containers for testing? <input checked="" type="checkbox"/>		Headspace issues acceptable? <input checked="" type="checkbox"/>		Holding time(s) acceptable? <input checked="" type="checkbox"/>			
Received for Lab by: (Signature) <i>[Signature]</i>		Date: <u>5/28/08</u> Temp: <u>2.2</u> °C Time: <u>940</u> ROK: <input checked="" type="checkbox"/> No		Preservative pH's acceptable? <input checked="" type="checkbox"/>		Was pH left unadjusted? <input checked="" type="checkbox"/>		_____			

ORIGINAL



CERTIFICATE OF ANALYSIS

Service Location HERITAGE ENVIRONMENTAL SERVICES, LLC COMMERCIAL LABORATORY OPERATIONS 7901 W. MORRIS ST. INDIANAPOLIS, IN 46231 (317)243-8304	Received 28-MAY-08	Project	Lab ID A811980
	Completed 06-JUN-08	PO Number DAVIS JUNCTION*****	
	Printed 11-JUN-08	Sampled 27-MAY-08 13:00	

Report To MIKE MAXWELL WEAVER BOOS AND GORDON 70 WEST MADISON SUITE 4250 CHICAGO, IL 60602	Bill To ACCOUNTS PAYABLE BFI WASTE SYSTEMS OF NORTH AMERICA INC. 26 WEST 580 SCHICK ROAD HANOVER PARK, IL 60133
--	--

Sample Description CLIENT ID: PHASE I MATRIX TYPE: NON-SPECIFIC WATER SUBMITTER CODE: 9016 DESCRIPTION

SEMI-VOLATILE ORGANICS (BASE/NEUTRAL/ACID FRACTIONS) SW846-8270C			NELAC:Y
Analyst: C. WILLHITE	Analysis Date: 04-JUN-08 22:00	Instrument: GC/MS SVOA	Test: O505.3.0

Parameter	Result	Det. Limit	Units
PHTHALIC ANHYDRIDE	BDL	50	ug/L
SURROGATE RECOVERY			
2-FLUOROPHENOL	37		% Rec
PHENOL-D5	28		% Rec
NITROBENZENE-D5	70		% Rec
2-FLUOROBIPHENYL	59		% Rec
2,4,6-TRIBROMOPHENOL	56		% Rec
TERPHENYL-D14	42		% Rec

1:5 Dilution
Unable to analyze sample at lower dilution due to high concentration of non-target analytes.

GC/MS SEPARATORY FUNNEL LIQUID-LIQUID EXTRACTION SW846-3510C			
Analyst: J. BREWER	Analysis Date: 02-JUN-08	Instrument: PREP	Test: P233.4.0

Parameter	Result	Det. Limit	Units
INITIAL WEIGHT OR VOLUME	1000		mL
FINAL VOLUME	1.0		mL

Sample Comments
BDL Below Detection Limit



Sample Comments

Sample was received on ice at temperature 2.2 C.
Sample chain of custody number 61659.

This Certificate shall not be reproduced, except in full,
without the written approval of the lab.

The sample results relate only to the analytes of interest tested
or to the sample as received by the lab.

Heritage Environmental Services, LLC certifies that the test results
indicated as NELAC (National Environmental Laboratory Accreditation
Conference) accredited (Yes for NELAC) meet all requirements of NELAC and
Illinois EPA Part 186 unless otherwise explained or justified as to the
the exact nature of the deviations.

Heritage Environmental Services, LLC is accredited under Illinois NELAC
accreditation number 100401.

Indiana SDWA Lab Accred. No. C-49-01

A handwritten signature in cursive script, appearing to read "Christine Sarkan".

Approved by: CHRISTINE SARKAN 11-JUN-08

Table A
Summary of Delisting Levels for
Fish Ingestion and Air Volatiles Pathway
DRAS Version 2 Work Around
Davis Junction Landfill

Constituent	Fish Ingestion Part of Overall Risk?*	Fish Ingestion Part of Overall HQ?*	Air Volatiles Part of Overall Risk?*	Air Volatiles Part of Overall HQ?*	Cancer Risk	Hazard Quotient (HQ)	Obs Concen***	DRAS Est. Risk**	DRAS Est. HQ**	Manually Calc Delsiting Level (mg/L)****	Delisting Level in Petition (mg/L)
Arsenic*	No	No	No	No	0	0	0.054	0	0	--	--
Barium	No	No	No	No	0	0	1.3	0	0	--	--
Benzene*	No	No	Yes	No	0.000001	0	0.027	3.58E-12	0	7,542	0.402
Benzene*	No	No	No	Yes	0	1	0.027	0	2.68E-08	1,007,463	0.402
Cadmium*	No	No	No	No	0	0	0.018	0	0	--	--
Carbon Disulfide	No	No	No	Yes	0	1	0.061	0	3.04E-09	20,065,789	118
Chromium	No	No	No	No	0	0	0.12	0	0	--	--
Dichloropropene, cis-1,3-	No	No	Yes	No	0.000001	0	0.01	8.29E-12	0	1,206	512,000
Cobalt	No	No	No	No	0	0	3.0	0	0	--	--
Copper	No	No	No	No	0	0	0.025	0	0	--	--
Diethyl phthalate	No	No	No	No	0	0	0.54	0	0	--	--
Endrin	No	No	No	No	0	0	0.0015	0	0	--	--
Ethylbenzene	No	No	No	Yes	0	1	0.25	0	2.18E-08	11,467,890	57.2
Isobutyl alcohol	No	No	No	No	0	0	3.7	0	0	--	--
Lead	No	No	No	No	0	0	0.18	0	0	--	--
Mercury	No	No	No	Yes	0	1	0.04	0	2.79E-05	1,434	0.22
Methanol	No	No	No	No	0	0	1.4	0	0	--	--
Methyl ethyl ketone	No	No	No	Yes	0	1	12	0	4.34E-08	276,497,696	599
Methylene chloride*	No	No	Yes	No	0.000001	0	0.58	4.94E-12	0	117,409	0.198
Methylene chloride*	No	No	No	Yes	0	1	0.58	0	2.29E-08	25,327,511	0.198
Methyl isobutyl ketone	No	No	No	No	0	0	1.8	0	0	--	--
Naphthalene	No	No	No	Yes	0	1	0.038	0	3.28E-07	115,854	6.51
Nickel	No	No	No	No	0	0	0.95	0	0	--	--
Cresol, p-	No	No	No	No	0	0	1.6	0	0	--	--
Phenol	No	No	No	No	0	0	0.91	0	0	--	--
Selenium	No	No	No	No	0	0	0.032	0	0	--	--
Styrene	No	No	No	Yes	0	1	0.087	0	2.34E-09	37,179,487	6.2
Tetrachloroethylene	No	No	Yes	No	0.000001	0	0.0059	4.67E-14	0	126,338	0.174
Tin	No	No	No	No	0	0	0.12	0	0	--	--
Toluene	No	No	No	Yes	0	1	0.47	0	2.43E-09	193,415,638	40.2
Trichloroethylene*	No	No	Yes	No	0.000001	0	0.53	1.43E-11	0	37,063	0.164
Vanadium	No	No	No	No	0	0	0.036	0	0	--	--
Vinyl chloride*	No	No	Yes	No	0.000001	0	0.44	6.93E-11	0	6,349	0.2
Vinyl chloride*	No	No	No	Yes	0	1	0.44	0	1.46E-07	3,013,699	0.2
Xylenes (total)	No	No	Yes	No	0.000001	0	1.1	0	0	--	--
Zinc	No	No	No	No	0	0	1.4	0	0	--	--
Dichloroethane, 1-1-	No	No	No	Yes	0	1	0.097	0	5.89E-09	16,468,591	99.8
Dichloroethane, 1,2-	No	No	Yes	No	0.000001	0	0.023	9.82E-12	0	2,342	0.0354
Dichlorobenzene, 1,4-*	No	No	Yes	No	0.000001	0	0.013	1.29E-12	0	10,078	0.473
Dichlorobenzene, 1,4-*	No	No	No	Yes	0	1	0.013	0	4.37E-10	29,748,284	0.473
Dioxane, 1,4-	No	No	Yes	No	0.000001	0	33.0	3.06E-10	0	107,843	100
Heptachlor*	No	No	Yes	No	0.000001	1	0.00053	6.61E-13	0	802	445,000
TCDD, 2,3,7,8-	No	No	Yes	No	0.000001	0	0.0000000044	4.69E-13	0	0.0094	0.00000147
Trichlorophenoxypropionic acid, 2,4, 5- (Silvex)	No	No	No	No	0	0	0.083	0	0	--	--
Dichlorophenoxyacetic acid, 2,4- (2,4-D)	No	No	No	No	0	0	0.39	0	0	--	--
Dimethylphenol, 2,4-	No	No	No	No	0	0	0.14	0	0	--	--
Acetone	No	No	No	No	0	0	20	0	0	--	--

*Both carcinogenic and noncarcinogenic effects modeled in DRAS (delisting levels were same for each constituent under both scenarios).

**Based on Surface Pathway Hazard Quotient and Surface Pathway Risk Output From DRAS (see attached).

*** Maximum observed concentration in historical data.

****Based upon equation listed in Item (3) of User Alert for DRAS Version 2.

Surface Pathway Hazard Quotient

Chemical Name	Waste Stream Total Concentration (mg/Kg)	Petitioned Waste Non-carcinogenic Hazard Quotient - Surface Water Exposure Pathways					Surface Pathway Aggregate Hazard Quotient
		Surface Water Ingestion Pathway	Air Particulate Inhalation Pathway	Fish Ingestion Pathway	Soil Ingestion Pathway	Air Volatile Inhalation Pathway	
Dichloroethane, 1,1-	9.70E-02	---	---	---	---	5.89E-09	5.89E-09
Dichloroethane, 1,2-	2.30E-02	---	---	---	---	---	---
Dioxane, 1,4-	3.30E+01	---	---	---	---	---	---
Trichlorophenoxypropionic acid, 2,4,5- (Silvex)	8.30E-02	---	---	---	---	---	---
Dichlorophenoxyacetic acid, 2,4- (2,4-D)	3.90E-01	---	---	---	---	---	---
Dimethylphenol, 2,4-	1.40E-01	---	---	---	---	---	---
Acetone	2.00E+01	---	---	---	---	---	---
Trichloroethylene	5.30E-01	---	---	---	---	---	---
Vanadium	3.60E-02	---	---	---	---	---	---
Vinyl chloride	4.40E-01	---	---	---	---	1.46E-07	1.46E-07
Arsenic	5.40E-02	---	---	---	---	---	---
Xylenes (total)	1.10E+00	---	---	---	---	2.90E-07	2.90E-07
Zinc	1.40E+00	---	---	---	---	---	---
Barium	1.30E+00	---	---	---	---	---	---
Dichlorobenzene, 1,4-	1.30E-02	---	---	---	---	4.37E-10	4.37E-10
Heptachlor	5.30E-04	---	---	---	---	---	---
Methylene chloride	5.80E-01	---	---	---	---	2.29E-08	2.29E-08
Methyl isobutyl ketone	1.80E+00	---	---	---	---	---	---

Surface Pathway Hazard Quotient

		Petitioned Waste Non-carcinogenic Hazard Quotient - Surface Water Exposure Pathways					
Chemical Name	Waste Stream Total Concentration (mg/Kg)	Surface Water Ingestion Pathway	Air Particulate Inhalation Pathway	Fish Ingestion Pathway	Soil Ingestion Pathway	Air Volatile Inhalation Pathway	Surface Pathway Aggregate Hazard Quotient
Naphthalene	3.80E-02	---	---	---	---	3.28E-07	3.28E-07
Nickel	9.50E-01	---	---	---	---	---	---
Selenium	3.20E-02	---	---	---	---	---	---
Trichloroethylene	5.30E-01	---	---	---	---	---	---
Vinyl chloride	4.40E-01	---	---	---	---	1.46E-07	1.46E-07
Benzene	2.70E-02	---	---	---	---	2.68E-08	2.68E-08
Tetrachloroethylene	5.90E-03	---	---	---	---	---	---
Arsenic	5.40E-02	---	---	---	---	---	---
Benzene	2.70E-02	---	---	---	---	8.94E-08	8.94E-08
Cresol, p-	1.60E-00	---	---	---	---	---	---
Phenol	9.10E-01	---	---	---	---	---	---
Styrene	8.70E-02	---	---	---	---	2.34E-09	2.34E-09
Tetrachloroethylene	5.90E-03	---	---	---	---	---	---
Trim	1.20E-00	---	---	---	---	---	---
Cadmium	1.80E-02	---	---	---	---	---	---
Methylene chloride	5.80E-01	---	---	---	---	2.29E-08	2.29E-08
Dichlorobenzene, 1,4-	1.30E-02	---	---	---	---	4.37E-10	4.37E-10
Heptachlor	5.30E-01	---	---	---	---	---	---

Surface Pathway Hazard Quotient

		Petitioned Waste Non-carcinogenic Hazard Quotient - Surface Water Exposure Pathways					
Chemical Name	Waste Stream Total Concentration (mg/Kg)	Surface Water Ingestion Pathway	Air Particulate Inhalation Pathway	Fish Ingestion Pathway	Soil Ingestion Pathway	Air Volatile Inhalation Pathway	Surface Pathway Aggregate Hazard Quotient
Toluene	4.70E-01	---	---	---	---	2.43E-09	2.43E-09
TCDD, 2,3,7,8-	4.40E-09	---	---	---	---	---	---
Cadmium	1.80E-02	---	---	---	---	---	---
Carbon disulfide	6.40E-02	---	---	---	---	5.04E-09	3.04E-09
Chromium	1.20E-01	---	---	---	---	---	---
Dichloropropene, cis-1,3	1.00E-02	---	---	---	---	---	---
Cobalt	3.00E+00	---	---	---	---	---	---
Copper	2.50E-02	---	---	---	---	---	---
Diethyl phthalate	5.40E-01	---	---	---	---	---	---
Endrin	1.00E-03	---	---	---	---	---	---
Ethylbenzene	2.50E-01	---	---	---	---	2.18E-08	2.18E-08
Isobutyl alcohol	9.70E+00	---	---	---	---	---	---
Lead	1.80E-01	---	---	---	---	---	---
Mercury	4.00E-02	---	---	---	---	2.79E-05	2.79E-05
Methanol	1.40E+00	---	---	---	---	---	---
Methyl ethyl ketone	1.20E+01	---	---	---	---	4.34E-08	4.34E-08
All Waste Constituents	---	---	---	---	---	2.90E-05	2.90E-05

Surface Pathway Risk

Chemical Name	Waste Stream Total Concentration (mg/Kg)	Petitioned Waste Carcinogenic Risk - Surface Water Exposure Pathways					
		Surface Water Ingestion Pathway	Air Particulate Inhalation Pathway	Fish Ingestion Pathway	Soil Ingestion Pathway	Air Volatile Inhalation Pathway	Surface Pathway Aggregate Cancer Risk
Dichloroethane, 1,1-	9.70E-02	---	---	---	---	---	---
Dichloroethane, 1,2-	2.30E-02	---	---	---	---	9.82E-12	9.82E-12
Dioxane, 1,4-	3.30E+01	---	---	---	---	3.06E-10	3.06E-10
Trichlorophenoxypropionic acid, 2,4,5- (Silvex)	8.30E-02	---	---	---	---	---	---
Dichlorophenoxyacetic acid, 2,4- (2,4-D)	3.90E-01	---	---	---	---	---	---
Dimethylphenol, 2,4-	1.40E-01	---	---	---	---	---	---
Acetone	2.00E+01	---	---	---	---	---	---
Trichloroethylene	5.30E-01	---	---	---	---	1.43E-11	1.43E-11
Vanadium	3.60E-02	---	---	---	---	---	---
Vinyl chloride	4.40E-01	---	---	---	---	6.93E-11	6.93E-11
Arsenic	5.40E-02	---	---	---	---	---	---
Xylenes (total)	1.10E+00	---	---	---	---	---	---
Zinc	1.40E+00	---	---	---	---	---	---
Barium	1.30E+00	---	---	---	---	---	---
Dichlorobenzene, 1,4-	1.30E-02	---	---	---	---	1.29E-12	1.29E-12
Heptachlor	5.30E-02	---	---	---	---	6.61E-13	6.61E-13
Methylene chloride	5.80E-01	---	---	---	---	4.94E-12	4.94E-12
Methylisobutylketone	1.80E+00	---	---	---	---	---	---

Surface Pathway Risk

Chemical Name	Waste Stream Total Concentration (mg/Kg)	Petitioned Waste Carcinogenic Risk - Surface Water Exposure Pathways					
		Surface Water Ingestion Pathway	Air Particulate Inhalation Pathway	Fish Ingestion Pathway	Soil Ingestion Pathway	Air Volatile Inhalation Pathway	Surface Pathway Aggregate Cancer Risk
Naphthalene	3.80E-02	---	---	---	---	---	---
Nickel	9.50E-01	---	---	---	---	---	---
Selenium	3.20E-02	---	---	---	---	---	---
Trichloroethylene	5.30E-01	---	---	---	---	1.43E-11	1.43E-11
Vinyl chloride	4.40E-01	---	---	---	---	6.93E-11	6.93E-11
Benzene	2.70E-02	---	---	---	---	3.58E-12	3.58E-12
Tetrachloroethylene	5.90E-03	---	---	---	---	4.67E-14	4.67E-14
Arsenic	5.40E-02	---	---	---	---	---	---
Benzene	2.70E-02	---	---	---	---	3.58E-12	3.58E-12
Cresol, p	1.60E+00	---	---	---	---	---	---
Phenol	9.10E-01	---	---	---	---	---	---
Styrene	8.70E-02	---	---	---	---	---	---
Tetrachloroethylene	5.90E-03	---	---	---	---	4.67E-14	4.67E-14
Lead	1.20E+01	---	---	---	---	---	---
Cadmium	1.80E-02	---	---	---	---	---	---
Methylene chloride	5.80E-01	---	---	---	---	4.94E-12	4.94E-12
Dichlorobenzene, 1,4-	1.30E-02	---	---	---	---	1.29E-12	1.29E-12
Heptachlor	5.30E-04	---	---	---	---	6.61E-13	6.61E-13

Surface Pathway Risk

Petitioned Waste Carcinogenic Risk - Surface Water Exposure Pathways							
Chemical Name	Waste Stream Total Concentration (mg/Kg)	Surface Water Ingestion Pathway	Air Particulate Inhalation Pathway	Fish Ingestion Pathway	Soil Ingestion Pathway	Air Volatile Inhalation Pathway	Surface Pathway Aggregate Cancer Risk
Toluene	4.70E-01	---	---	---	---	---	---
TCDD 2,3,7,8	4.40E-09	---	---	---	---	4.69E-13	4.69E-13
Cadmium	1.80E-02	---	---	---	---	---	---
Carbon disulfide	6.10E-02	---	---	---	---	---	---
Chromium	1.20E-01	---	---	---	---	---	---
Dichloropropene cis-1,3-	1.00E-02	---	---	---	---	8.29E-12	8.29E-12
Cobalt	3.00E+00	---	---	---	---	---	---
Copper	2.50E-02	---	---	---	---	---	---
Diethyl phthalate	5.40E-01	---	---	---	---	---	---
Endrin	1.50E-03	---	---	---	---	---	---
Ethylbenzene	2.50E-01	---	---	---	---	---	---
Isobutyl alcohol	3.70E+00	---	---	---	---	---	---
Lead	1.80E-01	---	---	---	---	---	---
Mercury	4.00E-02	---	---	---	---	---	---
Methanol	1.40E+00	---	---	---	---	---	---
Methyl ethyl ketone	1.20E+01	---	---	---	---	---	---
All Waste Constituents	---	---	---	---	---	5.12E-10	5.12E-10